

Superior Solutions for Sheet Metal Fabricators

MATE WILA TRUMPF STYLE PRESS BRAKE TOOLING

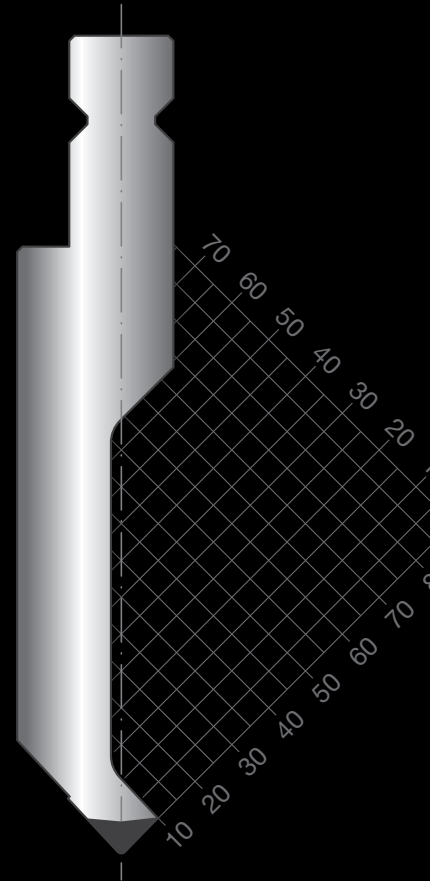

2017
PN

WORLDWIDE HEADQUARTERS:

1295 Lund Boulevard, Anoka, Minnesota 55303 USA
Tel +1.763.421.0230 Fax +1.763.421.0285
U.S. Toll Free: Tel 800.328.4492 Fax 800.541.0285
mate.com

MATE[®]
M
**PRECISION
TOOLING**

¡ABILIDAD | CALIDAD | SERVICIO | SOLUCIONES

MATE PRECISION TOOLING

COMPANY OVERVIEW

Founded in 1962, Mate has grown into a world-class manufacturer of superior products and solutions for sheet metal fabricators. We manufacture tooling for every major CNC punch press, supply and support a wide variety of precision ground press brake tooling, and offer a complete line of CO2 and fiber laser products. Our mission: To be the world's leading supplier of precision tooling for CNC punch presses. Our purpose: Helping sheet metal fabricators produce quality parts faster and more efficiently.



Headquartered in Anoka, Minnesota, in a 300,000 sq. ft. (28,000m²) state-of-the-art facility.

COMMITMENT TO QUALITY

Mate's dedication to quality is not just demonstrated in the products and services we provide, it is a part of every aspect of our business. This commitment was formally recognized when Mate was honored with the Minnesota Quality Award, Achievement level, for 2005. We integrate the Baldrige National Quality Program's criteria into the way we operate and continually measure our progress in improving our products, processes, and service.



CUSTOMER SATISFACTION GUARANTEED

Customer service is a critical component of Mate's business. Mate's sales engineers are experts in their field working on site with customers to solve fabricating issues. This commitment to customer satisfaction is extended around the world with Mate tooling experts available in every industrialized country. Customer education is available for every product Mate offers and is available 24/7 at mate.com. My.mate.com, a free web-based portal, allows registered users access to previously ordered drawings of special shapes and assemblies. Mate offers an extensive standard product line that can be delivered with same day or next day service and all our products come with a 100% satisfaction guarantee.

PRODUCTS AND SOLUTIONS THAT WORK

Mate's product engineering team currently holds several national and international patents and continues to develop products that push the boundaries of manufacturing technology. Our state-of-the-art customer solution center is an integral part of this process. It allows us to develop and test new tooling concepts and designs, and focus on proving the viability of value-added products while reducing the time needed to bring these products to market. The customer solution center also allows us to replicate the end user's environment and needs in every way. We work closely with the world's leading sheet metal fabricators and punch press manufacturers conducting research and evaluating new products. These partnerships bring to Mate a combined effort to continually offer customers superior products with proven solutions.

SPANNING THE GLOBE

Mate has over 80 dealers providing products and services in every industrialized country. Our dealers are thoroughly trained to assist with all tooling needs from simple hole punching to complex special applications. Mate recognized the need for an international specialist in the punch press tooling field and has been serving the international market since 1967. Our commitment to serving manufacturers around the world was formally recognized when Mate was presented with the President's "E" Certificate for Exports by the Secretary of Commerce in 1996. Today, more than 50% percent of Mate's revenue has come from outside the United States. We are committed to improving manufacturing technology around the world by helping established and emerging manufacturers produce quality parts faster and more efficiently.



TABLE OF CONTENTS AND MATERIAL SPECIFICATIONS

Wila Trumpf Style Press Brake Tooling

Bending Basics	4
----------------	---

Wila Trumpf Style Punches

Punch Overview	5
Punches	6-11
Blade Holders	12
Blades	13
Z Offset Holders	14
Z Offset Inserts	15
Radius/Flat Insert Holders	16
Radius/Flat Inserts	17

Wila Trumpf Style Dies

Die Overview/H55, H60 and H65 Pillar Dies	18-19
H100 and H120 Pillar Dies	20-21
H150 Pillar Dies	22
Nylon Inserts and Holders	23
Hemming Tool	24

Conversion Calculator

	25
--	----



Accessories

Punch Adapters	26
Die Adapters and Clamp Plates	27
Polyurethane Film and Holders	28
Reference Squares	29
Clamp Plates	30

Solution Gallery

Images	31
--------	----

Catalog Key:





Material Type	Base Material	Base/Core Hardness	Wear Surfaces Induction Hardened	Depth of Induction Hardness	Application	Tonnage limits
Gray 	C45	20-24 HRC	58-60 HRC	3-4mm (0.118-0.158)	Most common tool profiles, high force capable	50 to 100 tons/meter (17 to 34 tons/ft)
Red 	C45	20-24 HRC	58-60 HRC	3-4mm (0.118-0.158)	Tool profiles having thinner or taller cross sections	35 to 70 tons/meter (12 to 24 tons/ft)
Yellow 	42 CrMo4	20-24 HRC	58-60 HRC	3-4mm (0.118-0.158)	Tool profiles having thin cross sections	15 to 60 tons/meter (5 to 20 tons/ft)

HOW TO READ A MATE® PART NUMBER

Example: **012.345SX**

The numerical component identifies the tool profile. A profile is the image of a tool as shown in the catalog. The character component is used to identify the length of the tool.

The character component code is:

	S or SX	Standard	X indicates punch with safety button
	F or FX	Segmented	X indicates punch with safety button
	T or TX	300mm	X indicates punch with safety button
	D or DX	200mm	X indicates punch with safety button
	C or CX	100mm	X indicates punch with safety button

A number inside the gray arrow identifies the actual length of the tool in millimeters.

For example: 



BENDING BASICS

METRIC AIR BENDING CHART FORCE REQUIRED FOR 90° AIR BENDING, SHEET RESISTANCE R=45 kg/mm²

T	6	8	10	12	16	20	25	32	40	50	63	80	100	125	160	200	250	V
	4	5.5	7	8.5	11	14	17.5	22	28	35	45	55	71	89	113	140	175	b
	1	1.3	1.6	2	2.6	3.3	4	5	6.5	8	10	13	16	20	26	33	41	ir
0.5	3																	
0.6	4																	
0.8	7	5																
1	11	8	7	6														
1.2	16	12	10	8	6													
1.5	17		15	13	9	8												
2	27			22	17	13	11											
2.5	35				26	21	17	13										
3	38					30	24	19	15									
4	54						42	34	27	21								
5	67							52	42	33	26							
6	75								60	48	38	30						
8	107									85	68	53	43					
10	134										105	85	67	53				
12	153											120	96	78	60			
15	188												150	120	95	75		
20	270													215	170	135	108	

- Force in ton/meter **F**
- Thickness of material in mm **T**
- V-opening **V**
- Sheet Resistance **R**
- Inside radius **ir**
- Minimum flange length **b**

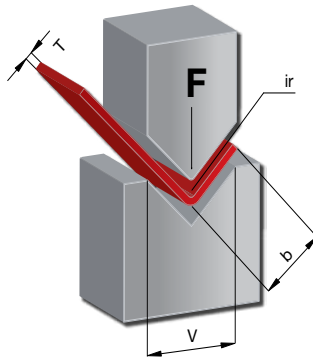

CALCULATION OF FORCE FOR AIR BENDING

$$F = \frac{T^2 \times 2 \times R}{1.4 \times V} = \dots \text{ Tons/mt}$$

R	
Aluminum	R=20-25 kg/mm ²
Mild steel	R=40-45 kg/mm ²
Stainless steel	R=65-70 kg/mm ²

TYPE OF BENDING	V- Width	Inside Radius	Springback	Bending precision	FEATURES
Air Bending	12T-15T	2T-2.5T	ABOUT +/- 45'	FORMS SURFACE with large radius	Low force requirement Greater springback
Bottoming	6T-12T	1T-2T	ABOUT +/- 30'	GOOD	Low force requirement Good precision
Coining	5T	0.5T-0.8T	ABOUT +/- 15'	GOOD	High force requirement 5-8 times greater than bottoming

SHEET THICKNESS (mm)	0.5 - 2.5	2.5 - 8	8 - 10	10 OR MORE
V - width (mm)	6 T	8 T	10 T	12 T

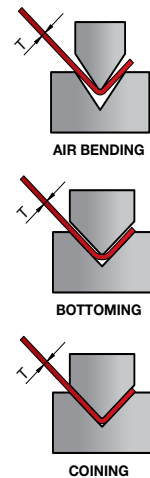

PUNCH LENGTHS

PUNCHES ARE AVAILABLE IN THE FOLLOWING STANDARD LENGTHS:

PUNCHES

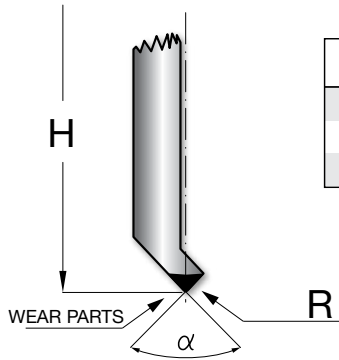

Legend	
H	= Height punch
α	= Degree punch
R	= Radius punch

100mm - (C)

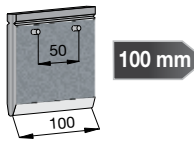

200mm - (D)

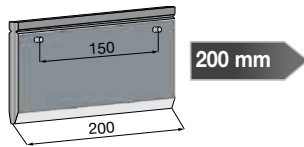

300mm - (T)

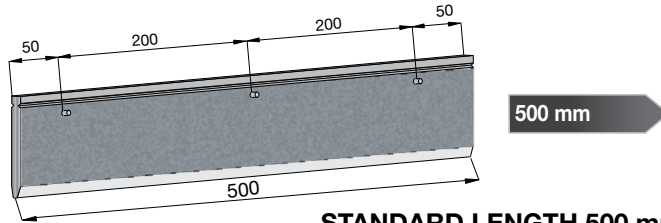
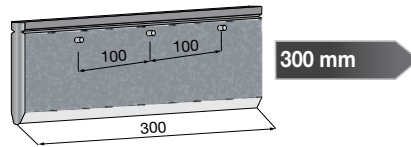

STANDARD LENGTH 500 mm - (S)

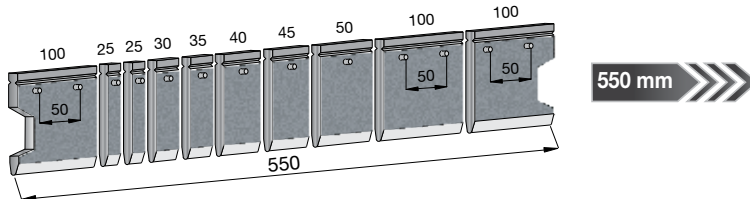

SECTIONED LENGTH 550mm - (F)

HORNS SCHEME STANDARD SECTIONING

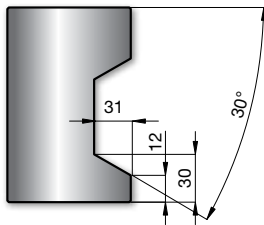

15.310	15.450	15.635	15.710	15.790
15.320	15.610	15.670	15.720	15.800
15.330	15.620	15.680	15.730	
15.370	15.630	15.700	15.750	



PUNCHES

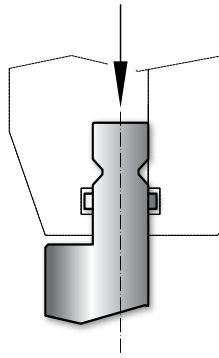

PRESSURE SURFACE ON THE HEAD

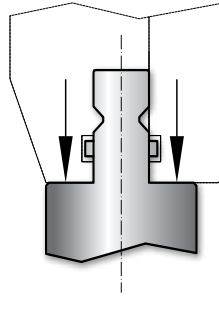

PRESSURE SURFACE ON THE SHOULDERS

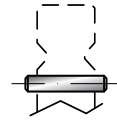

70.130

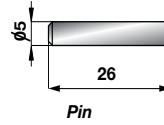

Pins are standard on all punches having a weight greater than 12.5 kg (27.6 lbs)



FAST CHANGE BUTTON

Fast change buttons are standard on all punches having a weight less than 12.5 kg (27.6 lbs)

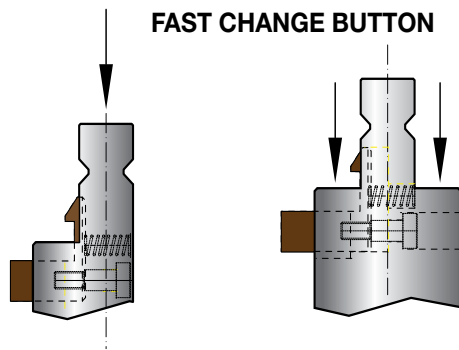

FAST CHANGE BUTTON

70.714

70.715

70.716

70.717

70.718

70.719

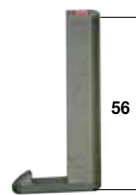
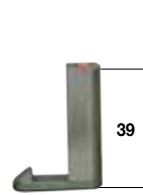
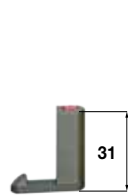

for: 15.010
15.310
15.610

for: 15.320
15.620

for: 15.330
15.630
15.635
15.902
15.904
15.905

for: 15.710
15.720
15.730
15.450
15.750
15.760

for: 15.370
15.670
15.680

for: 15.700
15.800



PUNCHES

- 100 mm
- 200 mm
- 300 mm
- 500 mm
- 550 mm

α	R	H	T/mt	Mt
15.330	86°	1.00	120.00	80

86°

- 100 mm
- 200 mm
- 300 mm
- 500 mm
- 550 mm

α	R	H	T/mt	Mt
15.710	86°	1.00	220.00	80

86°

- 100 mm
- 200 mm
- 300 mm
- 500 mm
- 550 mm

α	R	H	T/mt	Mt
15.370	86°	1.00	120.00	80

86°

- 100 mm
- 200 mm
- 300 mm
- 500 mm
- 550 mm

α	R	H	T/mt	Mt
15.700	86°	1.00	220.00	80

86°

kg Indicates weight is greater than 12.5kg.
 Pins are standard on all punches having a weight greater than 12.5 kg (27.6 lbs).
 Fast change buttons are standard on all punches having a weight less than 12.5 kg (27.6 lbs)



PUNCHES

- 100 mm
- 200 mm
- 300 mm
- 500 mm
- 550 mm

α	R	H	T/mt	Mt
15.310	60°	4.00	120.00	130

60°

- 100 mm
- 200 mm
- 300 mm
- 500 mm
- 550 mm

α	R	H	T/mt	Mt
15.730	60°	4.00	220.00	130

60°

- 100 mm
- 200 mm
- 300 mm
- 500 mm
- 550 mm

α	R	H	T/mt	Mt
15.320	28°	1.00	120.00	80

28°

- 100 mm
- 200 mm
- 300 mm
- 500 mm
- 550 mm

α	R	H	T/mt	Mt
15.720	28°	1.00	220.00	80

28°

Indicates weight is greater than 12.5kg.
 Pins are standard on all punches having a weight greater than 12.5 kg (27.6 lbs).
 Fast change buttons are standard on all punches having a weight less than 12.5 kg (27.6 lbs)



PUNCHES

- 100 mm
- 200 mm
- 300 mm
- 500 mm
- 550 mm

α	R	H	T/mt	Mt
15.450	28°	1.00	140.00	40

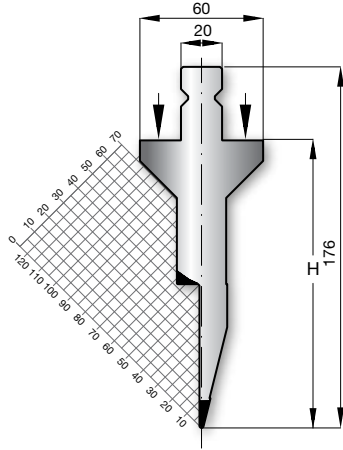

28°

- 100 mm
- 200 mm
- 300 mm
- 500 mm
- 550 mm

α	R	H	T/mt	Mt
15.750	28°	1.00	240.00	40

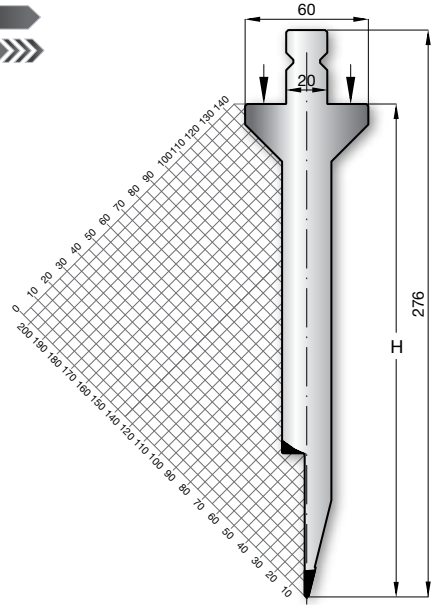

28°

- 100 mm
- 200 mm
- 300 mm
- 500 mm
- 550 mm

α	R	H	T/mt	Mt
15.670	86°	0.80	158.00	40

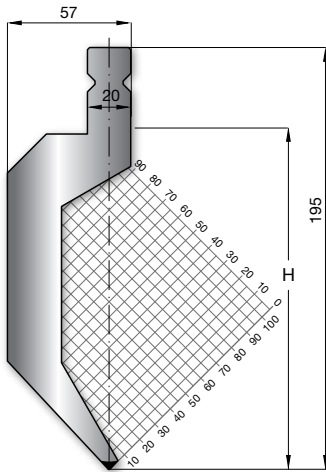

86°

- 100 mm
- 200 mm
- 300 mm
- 500 mm
- 550 mm

α	R	H	T/mt	Mt
15.635	86°	0.60	158.00	30

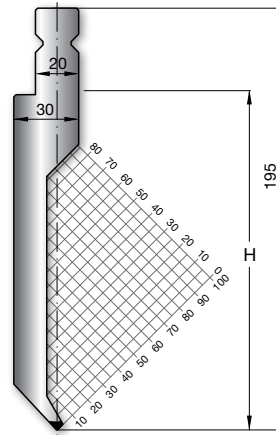

86°

 Indicates weight is greater than 12.5kg.
 Pins are standard on all punches having a weight greater than 12.5 kg (27.6 lbs).
 Fast change buttons are standard on all punches having a weight less than 12.5 kg (27.6 lbs)



PUNCHES

- 100 mm
- 200 mm
- 300 mm
- 500 mm
- 550 mm

15.630 α R H T/mt Mt 86° 0.80 158.00 80

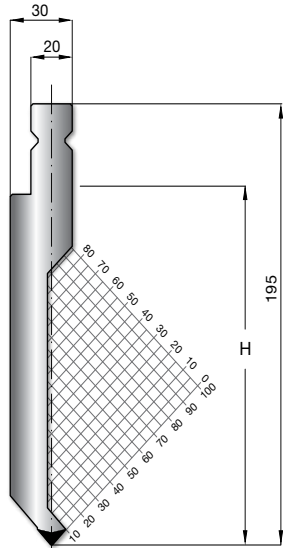

86°

- 100 mm
- 200 mm
- 300 mm
- 500 mm
- 550 mm

15.680 α R H T/mt Mt 60° 0.80 158.00 40

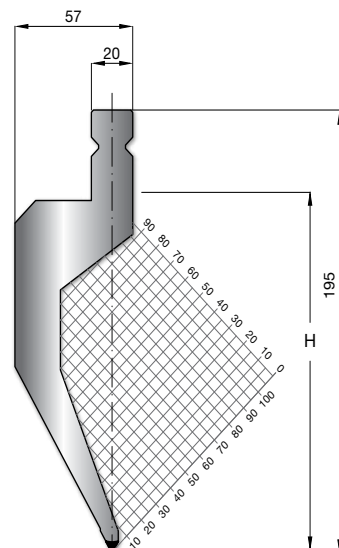

60°

- 100 mm
- 200 mm
- 300 mm
- 500 mm
- 550 mm

15.610 α R H T/mt Mt 28° 3.00 158.00 100

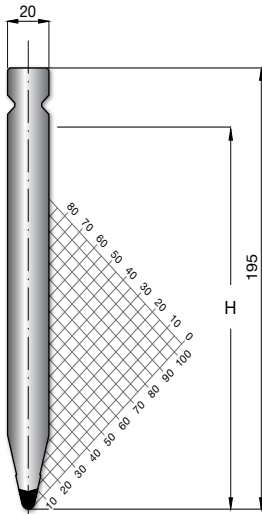

28°

- 100 mm
- 200 mm
- 300 mm
- 500 mm
- 550 mm

15.620 α R H T/mt Mt 28° 1.00 158.00 80

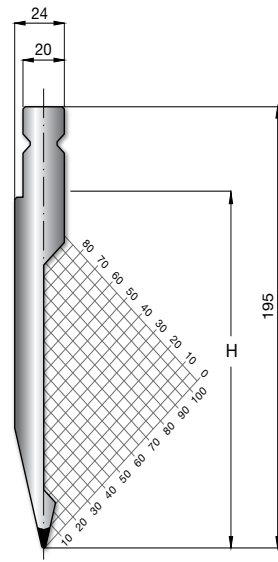

28°

kg Indicates weight is greater than 12.5kg.
 Pins are standard on all punches having a weight greater than 12.5 kg (27.6 lbs).
 Fast change buttons are standard on all punches having a weight less than 12.5 kg (27.6 lbs)



PUNCHES

- 100 mm
- 200 mm
- 300 mm
- 500 mm
- 550 mm

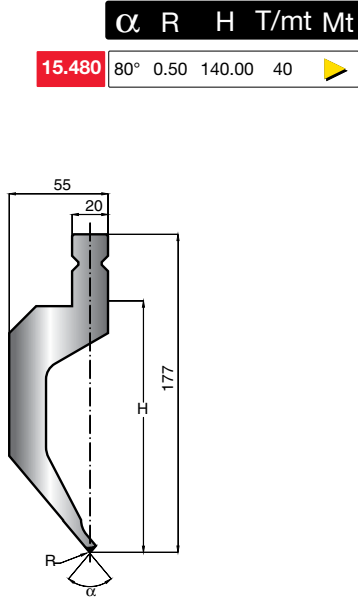

80°

- 100 mm
- 200 mm
- 300 mm
- 550 mm

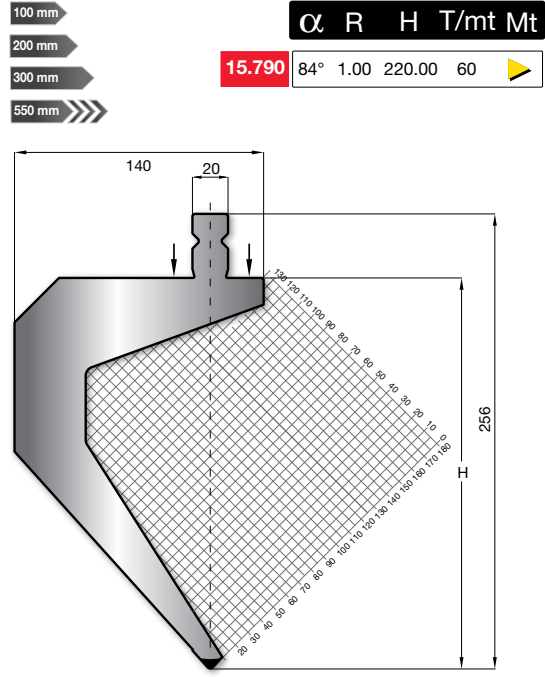

84°

- 100 mm
- 200 mm
- 300 mm
- 550 mm

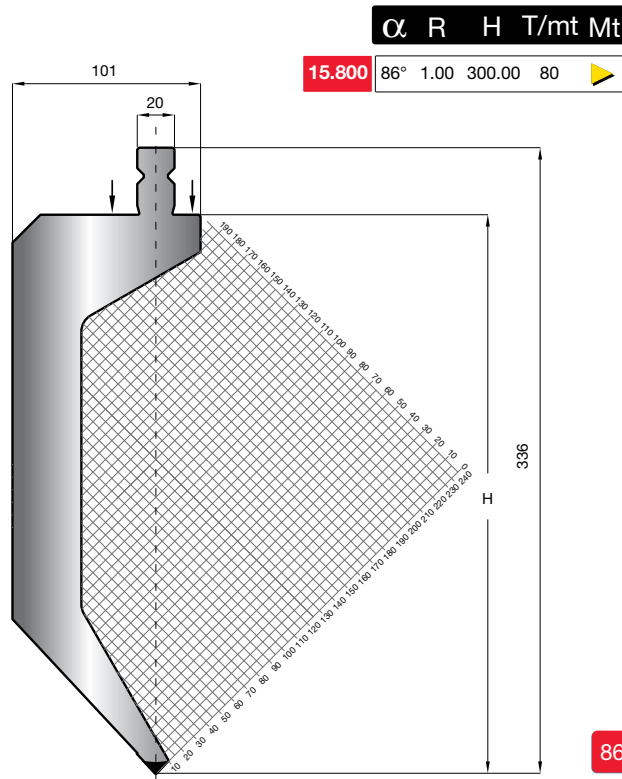

86°

 Indicates weight is greater than 12.5kg.
 Pins are standard on all punches having a weight greater than 12.5 kg (27.6 lbs).
 Fast change buttons are standard on all punches having a weight less than 12.5 kg (27.6 lbs)



BLADE HOLDERS

BLADE HOLDERS

Assembly scheme



H Mt

15.760 120.00

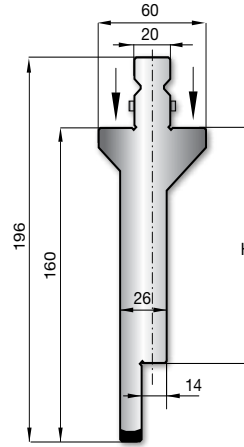
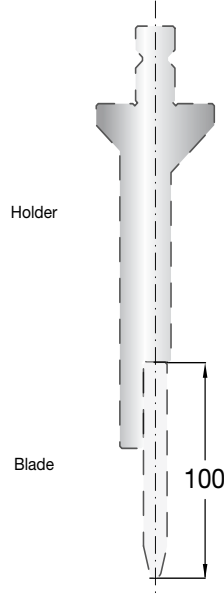

STANDARD LENGTH - (S)

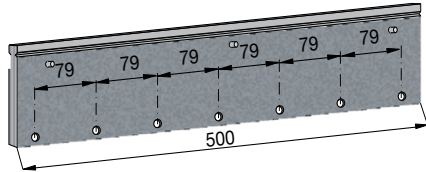

500 mm

SECTIONED LENGTH - (F)

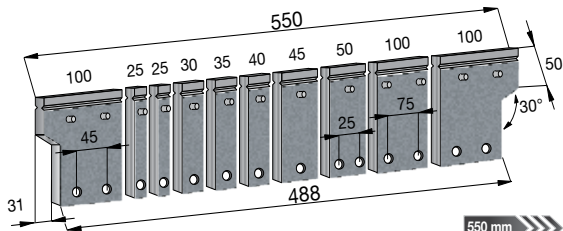

550 mm



BLADES

BLADES ARE AVAILABLE IN THE FOLLOWING STANDARD LENGTHS:

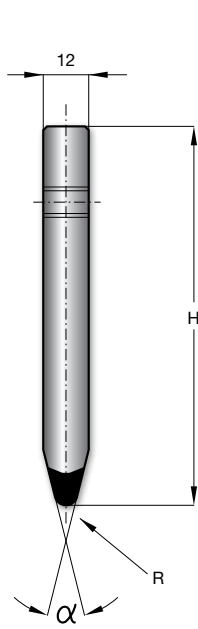

	α	R	H	T/mt	Mt
15.788	90°	2.00	100.00	100	▶
15.787	90°	1.50	100.00	100	▶
15.784	90°	1.00	100.00	100	▶
15.782	90°	0.50	100.00	100	▶
15.776	86°	1.00	100.00	100	▶
15.774	84°	1.00	100.00	100	▶
15.769	28°	6.00	100.00	100	▶
15.768	28°	5.00	100.00	100	▶
15.767	28°	4.00	100.00	100	▶
15.766	28°	3.00	100.00	100	▶
15.765	28°	2.00	100.00	100	▶
15.763	28°	1.00	100.00	100	▶
15.761	28°	0.50	100.00	100	▶

- 90°
- 86°
- 84°
- 28°

STANDARD LENGTH - (S)

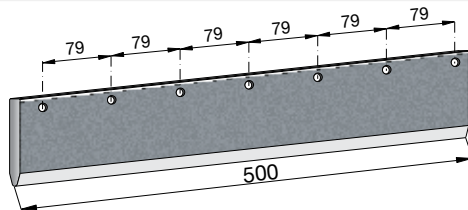

500 mm

SECTIONED LENGTH - (F)

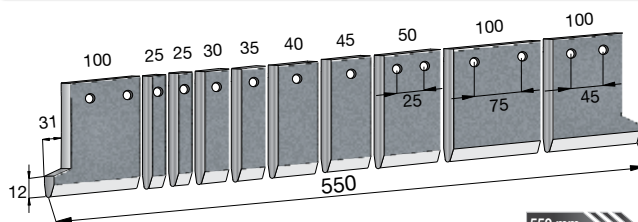

550 mm



Z OFFSET TOOL HOLDERS

415 mm
835 mm

	H1	H2	T/mt	Mt
15.050	62	64	100	▶

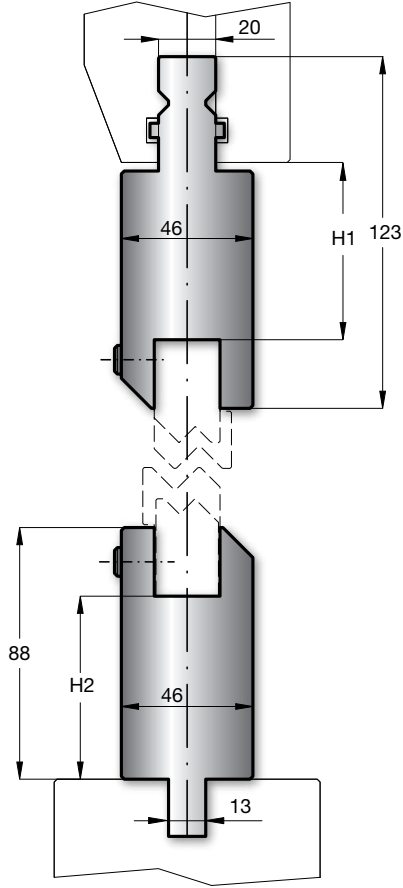

ASSEMBLY SCHEME

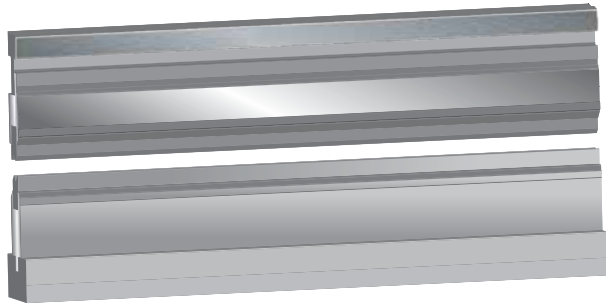

Z OFFSET TOOL INSERTS

415 mm
835 mm

Z α T/mt Mt

40.510	1.00	160°	100	▶
40.515	1.50	160°	100	▶
40.520	2.00	150°	100	▶
40.525	2.50	140°	100	▶

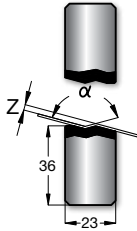

160°
150°
140°

415 mm
835 mm

Z α T/mt Mt

40.511	1.00	90°	100	▶
40.516	1.50	90°	100	▶
40.521	2.00	90°	100	▶
40.526	2.50	90°	100	▶
40.530	3.00	90°	100	▶
40.535	3.50	90°	100	▶
40.540	4.00	90°	100	▶
40.545	4.50	90°	100	▶
40.550	5.00	90°	100	▶
40.555	5.50	90°	100	▶
40.560	6.00	90°	100	▶
40.565	6.50	90°	100	▶
40.570	7.00	90°	100	▶
40.575	7.50	90°	100	▶
40.580	8.00	90°	100	▶

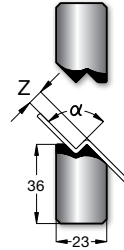

90°

415 mm
835 mm

Z α T/mt Mt

40.590	9.00	90°	100	▶
40.610	10.00	90°	100	▶
40.611	11.00	90°	100	▶
40.612	12.00	90°	100	▶

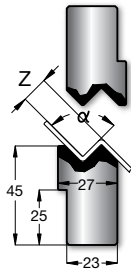

90°

415 mm
835 mm

Z α T/mt Mt

40.613	13.00	90°	100	▶
40.614	14.00	90°	100	▶
40.615	15.00	90°	100	▶

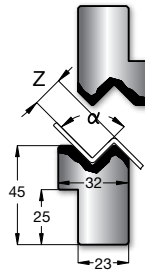

90°

415 mm
835 mm

T/mt Mt

40.500	100	▶
--------	-----	---

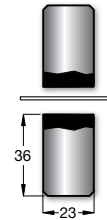

Flattening Insert

* MAXIMUM MATERIAL THICKNESS



RADIUS/FLAT INSERT HOLDERS

INSERT HOLDERS

412 mm
830 mm

H T/mt Mt

15.010 103.00 80 ▶

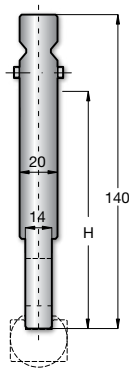

412 mm
830 mm

H T/mt Mt

15.014 160.00 80 ▶

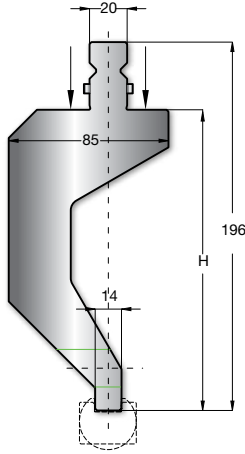

412 mm
830 mm

H T/mt Mt

15.018 220.00 80 ▶

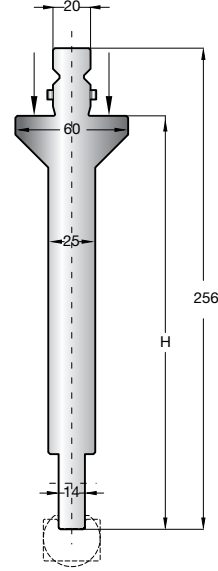

HALF LENGTH - (M)

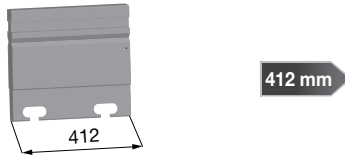

STANDARD LENGTH - (S)

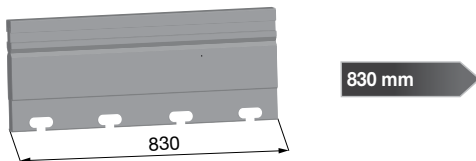

DIE SELECTION GUIDE

(Assumes air bending):

- Select the V opening:**
Calculate 2 times the punch radius plus 2 times the material thickness.

For example, a punch radius of 10mm and 2mm material = $(2 \times 10) + (2 \times 2) = 24\text{mm}$ V opening. When the exact V opening is not available, use the next nearest larger die.

- Select the V angle:**
It is recommended that the die V angle be smaller than the desired bend angle.

For example, to achieve a 90 degree bend, use a V angle less than 90 degrees such as a 60 degree, 45 degree or even a 30 degree.

If the result should be a 60 degree bend, use a die with a 45 degree or even a 30 degree angle.

If the result should be a 45 degree bend, use a die with a 30 degree angle.

Note that in general the material springback will be slightly greater using a radius punch than a standard punch.



RADIUS/FLAT INSERTS

INSERTS

415 mm → 835 mm →

	R	A	B	T/mt Mt
10.300	7.00	11.50		50 ▷
10.301	7.50	11.50		50 ▷
10.302	8.00	13.00		50 ▷
10.303	9.00	16.00		50 ▷
10.304	10.00	16.00		50 ▷
10.305	11.00	16.00		50 ▷
10.306	11.50	19.00		50 ▷
10.307	12.00	20.00		50 ▷

415 mm → 835 mm →

	R	A	B	T/mt Mt
11.300	7.00	11.50		100 ▷
11.301	7.50	11.50		100 ▷
11.302	8.00	13.00		100 ▷
11.303	9.00	16.00		100 ▷
11.304	10.00	16.00		100 ▷
11.305	11.00	16.00		100 ▷
11.306	11.50	19.00		100 ▷
11.307	12.00	20.00		100 ▷

10.308	12.50	16.00	21.00	50 ▷
10.309	13.00	17.00	23.00	50 ▷
10.310	14.00	19.00	25.00	50 ▷
10.311	15.00	20.00	27.00	50 ▷
10.312	16.00	21.00	28.00	50 ▷
10.313	17.00	21.50	31.50	50 ▷
10.314	17.50	22.00	32.00	50 ▷
10.315	19.00	25.00	32.00	50 ▷
10.316	20.00	24.00	34.00	50 ▷
10.317	22.50	25.00	33.00	50 ▷
10.318	25.00	29.00	39.00	50 ▷
10.319	27.50	34.00	44.00	50 ▷
10.320	30.00	34.00	44.00	50 ▷
10.321	35.00	45.00	55.00	50 ▷
10.322	40.00	45.00	55.00	50 ▷
10.323	45.00	50.00	60.00	50 ▷
10.324	50.00	54.00	64.00	50 ▷

11.308	12.50	16.00	21.00	100 ▷
11.309	13.00	17.00	23.00	100 ▷
11.310	14.00	19.00	25.00	100 ▷
11.311	15.00	20.00	27.00	100 ▷
11.312	16.00	21.00	28.00	100 ▷
11.313	17.00	21.50	31.50	100 ▷
11.314	17.50	22.00	32.00	100 ▷
11.315	19.00	25.00	32.00	100 ▷
11.316	20.00	24.00	34.00	100 ▷
11.317	22.50	25.00	33.00	100 ▷
11.318	25.00	29.00	39.00	100 ▷
11.319	27.50	34.00	44.00	100 ▷
11.320	30.00	34.00	44.00	100 ▷
11.321	35.00	45.00	55.00	100 ▷
11.322	40.00	45.00	55.00	100 ▷
11.323	45.00	50.00	60.00	100 ▷
11.324	50.00	54.00	64.00	100 ▷



10.325		17.00	22.00	100 ▷
--------	--	-------	-------	-------

Radius/flat insert sold with bolt assembly.

HALF LENGTH - (M)	STANDARD LENGTH - (S)	BOLT ASSEMBLY	ASSEMBLY SCHEME
<p>415 mm →</p>	<p>835 mm →</p>	<p>40.002</p>	

MATERIAL TYPE	
Mt ▷	NON-HARDENED
Mt ▷	STEEL C45 (UNI EN 10083 W.1. : 1.1191) INDUCTION TEMPERED (58-60 HRC) ON WEAR PARTS
Mt ▷	STEEL C45 (UNI EN 10083 W.1. : 1.1191) HARDENED R=80-85 kg/mm² INDUCTION TEMPERED (58-60 HRC) ON WEAR PARTS
Mt ▷	STEEL 42 CRMO4 (UNI EN 10083 W.1. : 1.7225) HARDENED R=95-105 kg/mm² NITRIDED (58-60 HRC) ON WEAR PARTS



DIES

H=55, 60, and 65

- 100 mm
- 200 mm
- 300 mm
- 500 mm
- 550 mm

Legend	
F	= bottom
R	= radius
P	= flat

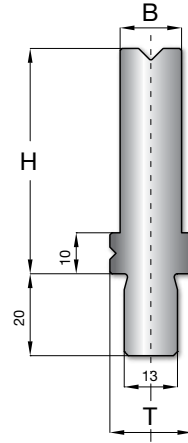
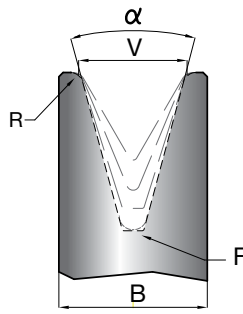

24.001		24.009		24.017		24.101	
24.002		24.010		24.018		24.102	
24.003		24.011		24.019		24.104	
24.004		24.012		24.035		24.106	
24.005		24.013		24.040		24.108	
24.006		24.014		24.050		24.109	
24.007		24.015		24.060		24.110	
24.008		24.016		24.100			

STANDARD DIE LENGTHS

- 100 mm
- 200 mm
- 300 mm
- 500 mm
- 550 mm

LENGTH - C

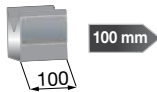

LENGTH - D

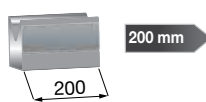

LENGTH - T

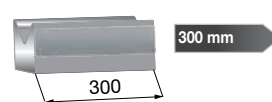

STANDARD LENGTH - M

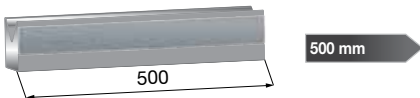

SECTIONED LENGTH - F

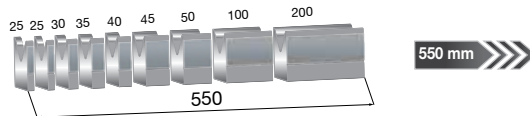

DIES

H=55, 60, and 65

90° 88° 85° 60° 30°

100 mm 200 mm 300 mm 500 mm 550 mm

α V R H B T F T/m Mt

24.001	90°	6	0,4	55	15	20	R 0,5	100	▶
24.002	90°	8	0,5	55	15	20	R 0,5	100	▶
24.003	90°	10	1,0	55	20	20	R 0,5	100	▶
24.005	90°	12	1,5	55	20	20	R 0,5	100	▶
24.007	90°	16	2,0	55	30	30	R 0,5	100	▶
24.004	88°	10	1,0	55	20	20	R 0,5	100	▶
24.006	88°	12	1,5	55	20	20	R 0,5	100	▶
24.008	88°	16	2,0	55	30	30	R 0,5	100	▶
24.009	88°	20	2,0	55	30	30	R 0,5	100	▶
24.010	88°	24	3,0	55	40	40	R 0,5	100	▶
24.100	85°	4	0,6	55	8	20	R 0,5	50	▶
24.101	85°	6	0,8	55	15	20	R 0,5	70	▶
24.102	85°	8	1,0	55	15	20	R 0,5	70	▶
24.104	85°	10	1,0	55	20	20	R 0,5	100	▶
24.106	85°	12	1,5	55	20	20	R 0,5	100	▶
24.108	85°	16	2,0	55	30	30	R 0,5	100	▶
24.109	85°	20	2,0	55	30	30	R 0,5	100	▶
24.110	85°	24	3,0	55	40	40	R 0,5	100	▶
24.011	85°	32	4,0	55	50	50	R 3,0	100	▶
24.012	85°	40	4,0	55	55	55	R 4,0	100	▶
24.040	60°	40	5,0	55	55	55	R 5,0	80	▶
24.050	60°	50	5,0	55	70	70	P 15,0	100	▶
24.060	60°	60	7,0	65	80	80	P 15,0	60	▶
24.013	30°	6	0,6	55	15	20	R 1,0	35	▶
24.014	30°	8	0,8	55	15	20	P 2,0	35	▶
24.015	30°	10	1,0	55	20	20	P 2,0	50	▶
24.016	30°	12	1,5	55	20	20	P 2,0	40	▶
24.017	30°	16	2,0	55	30	30	P 5,0	45	▶
24.019	30°	20	2,5	55	35	35	P 5,0	50	▶
24.018	30°	24	3,0	55	40	40	P 8,0	50	▶
24.035	30°	32	4,0	60	60	60	P 10,0	50	▶



DIES

H=100 and 120

- 100 mm
- 200 mm
- 300 mm
- 500 mm
- 550 mm

Legend	
F	= bottom
R	= radius
P	= flat

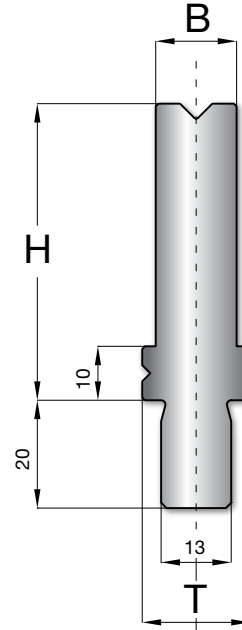
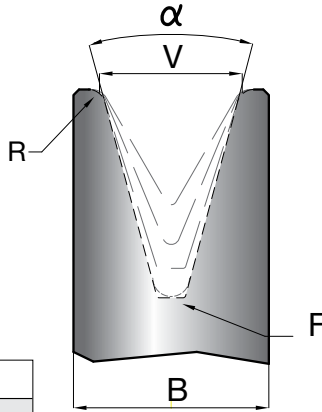

25.100		25.112		25.208		25.404		25.500	
25.101		25.113		25.209		25.405		25.501	
25.102		25.114		25.210		25.406		25.502	
25.103		25.115		25.300		25.407		25.503	
25.104		25.116		25.301		25.408		25.504	
25.105		25.201		25.302		25.409			
25.106		25.202		25.303		25.410			
25.107		25.203		25.304		25.421			
25.108		25.204		25.400		25.422			
25.109		25.205		25.401		25.423			
25.110		25.206		25.402		25.424			
25.111		25.207		25.403		25.425			



H=100 and 120

100 mm → 200 mm → 300 mm → 500 mm → 550 mm >>>>

86° 84° 80° 60° 30°

	α	V	R	H	B	T	F	T/m	Mt
25.100	86°	4	0,6	100	8	20	R 0,6	30	▶
25.101	86°	6	0,6	100	20	20	R 0,6	100	▶
25.102	86°	8	0,8	100	20	20	R 0,8	100	▶
25.103	86°	10	1,0	100	20	20	R 1,0	100	▶
25.104	86°	12	1,0	100	25	25	R 1,0	100	▶
25.105	86°	16	1,6	100	30	30	R 1,6	100	▶
25.106	86°	20	2,0	100	30	30	R 2,0	100	▶
25.107	86°	24	2,5	100	35	35	R 2,5	100	▶
25.108	86°	30	3,0	100	45	45	R 3,0	100	▶
25.109	86°	40	3,0	100	55	55	R 3,0	100	▶
25.110	86°	50	3,0	100	75	75	R 5,0	100	▶
25.200	84°	4	0,6	100	8	20	R 0,6	30	▶
25.300	84°	5	0,6	100	8	20	R 0,6	25	▶
25.301	84°	6	0,6	100	10	20	R 0,6	25	▶
25.201	84°	6	0,6	100	20	20	R 0,6	100	▶
25.302	84°	8	0,8	100	12	20	R 0,6	35	▶
25.202	84°	8	0,8	100	20	20	R 0,8	100	▶
25.303	84°	10	1,0	100	14	20	R 0,8	40	▶
25.203	84°	10	1,0	100	20	20	R 1,0	100	▶
25.304	84°	12	1,0	100	16	20	R 1,0	40	▶
25.204	84°	12	1,0	100	25	25	R 1,0	100	▶
25.205	84°	16	1,6	100	30	30	R 1,6	100	▶
25.206	84°	20	2,0	100	30	30	R 2,0	100	▶
25.207	80°	24	2,5	100	35	35	R 2,5	100	▶
25.208	80°	30	5,0	100	45	45	R 3,0	100	▶
25.209	80°	40	5,0	100	55	55	R 3,0	100	▶
25.210	80°	50	5,0	100	65	65	R 5,0	100	▶
25.111	80°	60	5,0	100	75	75	R 5,0	100	▶
25.112	80°	70	5,0	100	85	85	R 5,0	100	▶
25.113	80°	80	5,0	100	100	100	R 5,0	100	▶
25.114	80°	90	8,0	120	110	110	R 5,0	100	▶
25.115	80°	100	8,0	120	120	120	R 5,0	100	▶
25.116	60°	120	8,0	120	145	145	P 38	100	▶
25.400	30°	4	0,6	100	15	20	R 0,6	20	▶
25.500	30°	5	0,6	100	15	20	R 0,6	15	▶
25.501	30°	6	0,6	100	16	20	R 0,6	17	▶
25.401	30°	6	0,6	100	20	20	R 0,6	40	▶
25.421	30°	6	3,0	100	20	20	R 0,6	40	▶
25.502	30°	8	1,0	100	17	20	R 1,0	20	▶
25.402	30°	8	1,0	100	20	20	R 1,0	40	▶
25.422	30°	8	3,0	100	20	20	R 1,0	40	▶
25.503	30°	10	1,0	100	18	20	R 1,0	20	▶
25.403	30°	10	1,0	100	20	20	R 1,0	40	▶
25.423	30°	10	3,0	100	20	20	R 1,0	40	▶
25.504	30°	12	1,0	100	21,5	25	R 1,0	25	▶
25.404	30°	12	1,0	100	25	25	R 1,0	40	▶
25.424	30°	12	3,0	100	25	25	R 1,0	40	▶
25.405	30°	16	1,6	100	30	30	R 1,6	50	▶
25.425	30°	16	3,0	100	30	30	R 1,6	50	▶
25.406	30°	20	2,0	100	35	35	R 2,0	60	▶
25.407	30°	24	2,5	100	40	40	R 2,5	65	▶
25.408	30°	30	3,0	100	55	55	R 3,0	90	▶
25.409	30°	40	5,0	100	60	60	R 5,0	90	▶
25.410	30°	50	5,0	100	75	75	R 5,0	100	▶



DIES

H=150

- 100 mm
- 200 mm
- 300 mm
- 500 mm
- 550 mm

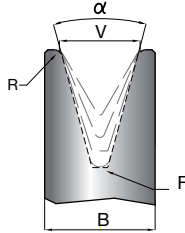

Legend
 F = bottom
 R = radius
 P = flat

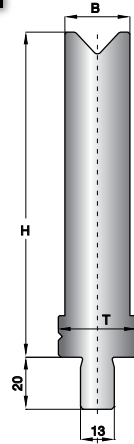

- 100 mm
- 200 mm
- 300 mm
- 500 mm
- 550 mm

25.601	25.623	25.902
25.602	25.624	25.903
25.603	25.625	25.904
25.604	25.626	25.905
25.605	25.627	25.906
25.606	25.628	25.907
25.607	25.629	25.908
25.621	25.630	25.909
25.622	25.901	

α V R H B T F T/m Mt

25.601	86°	6	0,6	150	20	20	R 0,6	100	▶
25.602	86°	8	0,8	150	20	20	R 0,8	100	▶
25.603	86°	10	1,0	150	20	20	R 1,0	100	▶
25.604	86°	12	1,0	150	25	25	R 1,0	100	▶
25.605	86°	16	1,6	150	30	30	R 1,6	100	▶
25.606	86°	20	2,0	150	30	30	R 2,0	100	▶
25.607	86°	24	2,5	150	35	35	R 2,5	100	▶
25.621	84°	6	0,6	150	20	20	R 0,6	100	▶
25.622	84°	8	0,8	150	20	20	R 0,8	100	▶
25.623	84°	10	1,0	150	20	20	R 1,0	100	▶
25.624	84°	12	1,0	150	25	25	R 1,0	100	▶
25.625	84°	16	1,6	150	30	30	R 1,6	100	▶
25.626	84°	20	2,0	150	30	30	R 2,0	100	▶
25.627	80°	24	2,5	150	35	35	R 2,5	100	▶
25.628	80°	30	5,0	150	45	45	R 3,0	100	▶
25.629	80°	40	5,0	150	55	55	R 3,0	100	▶
25.630	80°	50	5,0	150	65	65	R 5,0	100	▶
25.901	30°	6	0,6	150	20	20	R 0,6	30	▶
25.902	30°	8	1,0	150	20	20	R 1,0	40	▶
25.903	30°	10	1,0	150	20	20	R 1,0	40	▶
25.904	30°	12	1,0	150	25	25	R 1,0	40	▶
25.905	30°	16	1,6	150	30	30	R 1,6	50	▶
25.906	30°	20	2,0	150	35	35	R 2,0	60	▶
25.907	30°	24	2,5	150	40	40	R 2,5	65	▶
25.908	30°	30	3,0	150	55	55	R 3,0	90	▶
25.909	30°	40	5,0	150	60	60	R 5,0	90	▶

- 86°
- 84°
- 80°
- 30°



NYLON INSERTS AND HOLDERS

NYLON INSERTS

V α			V α		
32.306	6	30°	32.606	6	60°
32.308	8	30°	32.608	8	60°
32.310	10	30°	32.610	10	60°
32.406	6	45°	32.612	12	60°
32.408	8	45°	32.616	16	60°
32.410	10	45°	32.806	6	88°
32.412	12	45°	32.808	8	88°
			32.810	10	88°
			32.812	12	88°
			32.816	16	88°

MEDIUM

415 mm
835 mm

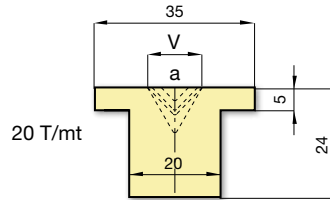

ASSEMBLY SCHEME

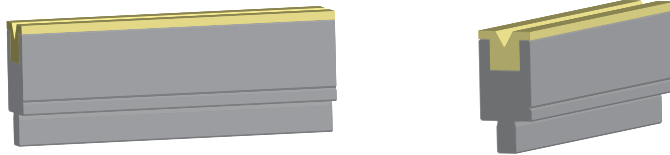

NYLON INSERT HOLDERS

415 mm
835 mm

H	Mt
22.005	95.00

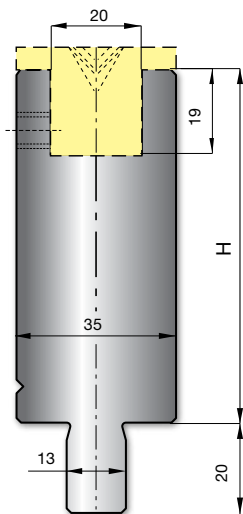

415 mm
835 mm

H	Mt
22.004	50.00

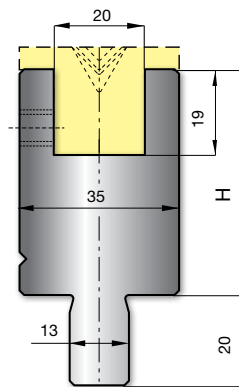

HEMMING TOOL

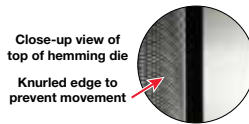
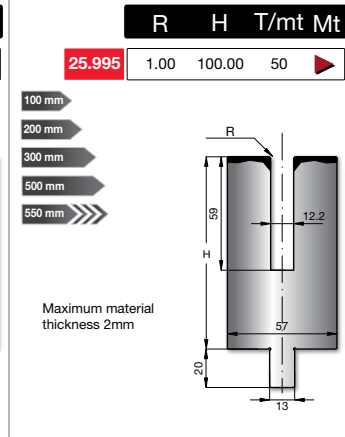
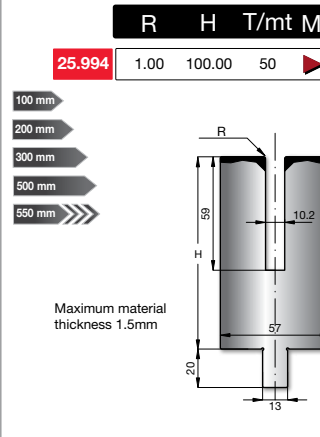
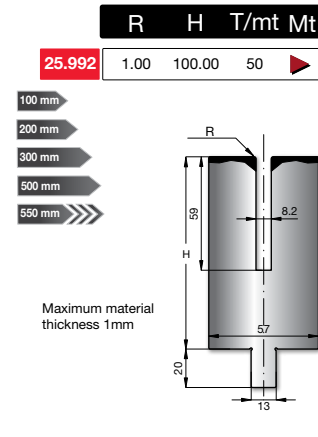
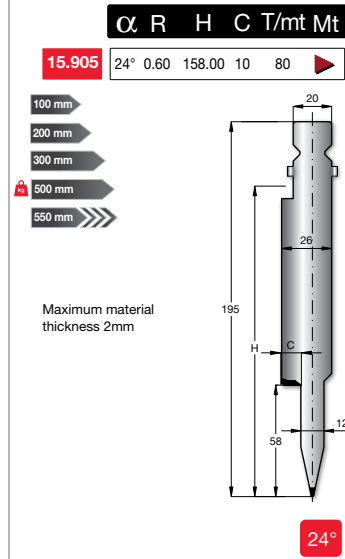
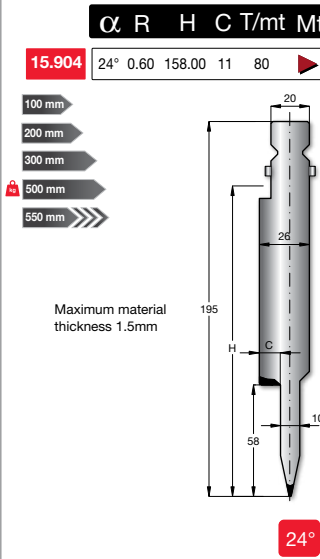
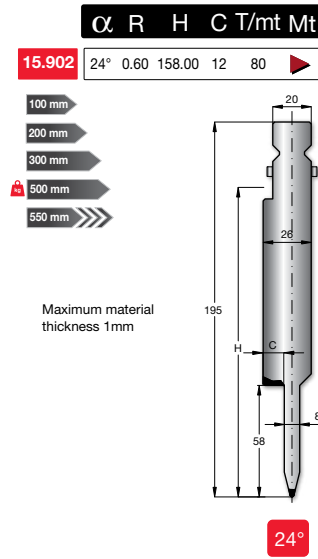

HORNS SCHEME STANDARD SECTIONING

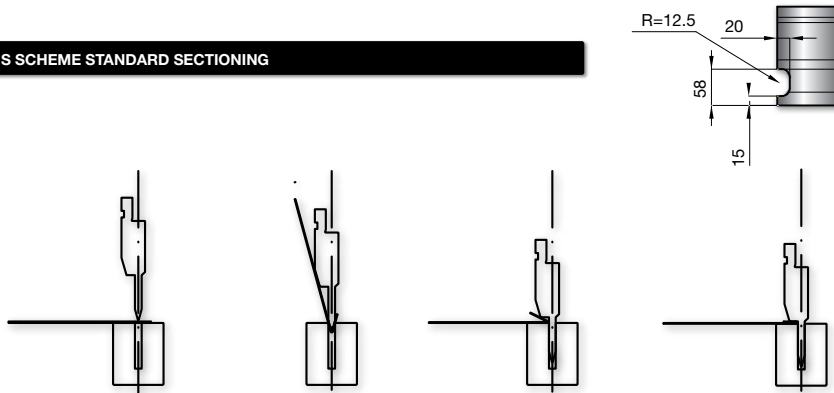

Indicates weight is greater than 12.5kg.
Pins are standard on all punches having a weight greater than 12.5 kg (27.6 lbs).
Fast change buttons are standard on all punches having a weight less than 12.5 kg (27.6 lbs)



INCH TO METRIC / METRIC TO INCH REFERENCE GUIDE

CONVERSION CHART

mm	inch
0.01mm	0.0004
0.02mm	0.0008
0.03mm	0.0012
0.04mm	0.0016
0.05mm	0.0020
0.06mm	0.0024
0.07mm	0.0028
0.08mm	0.0031
0.09mm	0.0035
0.10mm	0.0039
0.25mm	0.0098
0.50mm	0.0197
0.75mm	0.0295
1.00mm	0.0394
1.50mm	0.0591
2.00mm	0.0787
2.50mm	0.0984
3.00mm	0.1181
3.50mm	0.1378
4.00mm	0.1575
4.50mm	0.1772
5.00mm	0.1969
6.00mm	0.2362
7.00mm	0.2756
8.00mm	0.3150
9.00mm	0.3543
10.00mm	0.3937
11.00mm	0.4331
12.00mm	0.4724
13.00mm	0.5118
14.00mm	0.5512
15.00mm	0.5906
16.00mm	0.6299
17.00mm	0.6693
18.00mm	0.7087
19.00mm	0.7480
20.00mm	0.7874
21.00mm	0.8268
22.00mm	0.8661
23.00mm	0.9055
24.00mm	0.9449
25.00mm	0.9843
26.00mm	1.0236
27.00mm	1.0630
28.00mm	1.1024
29.00mm	1.1417
30.00mm	1.1811
31.00mm	1.2205
32.00mm	1.2598
33.00mm	1.2992
34.00mm	1.3386
35.00mm	1.3780
36.00mm	1.4173
37.00mm	1.4567
38.00mm	1.4961
39.00mm	1.5354
40.00mm	1.5748
50.00mm	1.9685
60.00mm	2.3622
65.00mm	2.5591
70.00mm	2.7559
75.00mm	2.9528
80.00mm	3.1496
90.00mm	3.5433
100.00mm	3.9370

inch	inch	mm
	0.0001	0.003mm
	0.0010	0.03mm
	0.0020	0.05mm
	0.0030	0.08mm
	0.0040	0.10mm
	0.0050	0.13mm
1/128	0.0078	0.20mm
	0.0100	0.25mm
	0.0120	0.30mm
	0.0150	0.38mm
1/64	0.0156	0.40mm
	0.0300	0.76mm
1/32	0.0313	0.79mm
3/64	0.0469	1.19mm
	0.0600	1.52mm
1/16	0.0625	1.59mm
5/64	0.0781	1.98mm
	0.0900	2.29mm
3/32	0.0938	2.38mm
7/64	0.1094	2.78mm
	0.1200	3.05mm
1/8	0.1250	3.18mm
9/64	0.1406	3.57mm
5/32	0.1563	3.97mm
3/16	0.1875	4.76mm
7/32	0.2188	5.56mm
1/4	0.2500	6.35mm
9/32	0.2813	7.14mm
5/16	0.3125	7.94mm
3/8	0.3750	9.53mm
7/16	0.4375	11.11mm
1/2	0.5000	12.70mm
9/16	0.5625	14.29mm
5/8	0.6250	15.88mm
3/4	0.7500	19.05mm
7/8	0.8750	22.23mm
1 1/8	1.1250	28.58mm
1 1/4	1.2500	31.75mm
1 1/2	1.5000	38.10mm
1 3/4	1.7500	44.45mm
2	2.0000	50.80mm
2 1/4	2.2500	57.15mm
2 1/2	2.5000	63.50mm
2 3/4	2.7500	69.85mm
3	3.0000	76.20mm
3 1/2	3.5000	88.90mm
4	4.0000	101.60mm
4 1/2	4.5000	114.30mm
5	5.0000	127.00mm
5 1/2	5.5000	139.70mm
6	6.0000	152.40mm
12	12.0000	304.80mm

inch	mm
0.0001	0.003mm
0.0010	0.025mm
0.0100	0.254mm
0.1000	2.54mm
1.0000	25.40mm

mm	inch
0.01mm	0.0004
0.10mm	0.0039
1.00mm	0.0394

mm	inch	feet
1000mm	39.4	3.3
1050mm	41.3	3.4
1250mm	49.2	4.1
1500mm	59.1	4.9
2000mm	78.7	6.6
2050mm	80.7	6.7
2500mm	98.4	8.2
3000mm	118.1	9.8
3050mm	120.1	10.0
3500mm	137.8	11.5
4000mm	157.5	13.1
4050mm	159.4	13.3
4500mm	177.2	14.8
5000mm	196.9	16.4

feet	inch	mm
1 ft	12 inch	305mm
2 ft	24 inch	610mm
3 ft	36 inch	914mm
4 ft	48 inch	1219mm
5 ft	60 inch	1524mm
6 ft	72 inch	1829mm
7 ft	84 inch	2134mm
8 ft	96 inch	2438mm
9 ft	108 inch	2743mm
10 ft	120 inch	3048mm
11 ft	132 inch	3353mm
12 ft	144 inch	3658mm



metal gauges	gauge size	aluminum & brass	mild steel	stainless steel
	8GA	.129(3.28)	.164(4.17)	.172(4.37)
	9GA	.114(2.90)	.150(3.81)	.156(3.96)
	10GA	.102(2.59)	.135(3.43)	.141(3.58)
	11GA	.091(2.31)	.120(3.05)	.125(3.18)
	12GA	.081(2.06)	.105(2.67)	.109(2.77)
	13GA	.072(1.83)	.090(2.29)	.094(2.39)
	14GA	.064(1.63)	.075(1.91)	.078(1.98)
	16GA	.051(1.30)	.060(1.52)	.063(1.60)
	18GA	.040(1.02)	.048(1.22)	.050(1.27)
20GA	.032(0.81)	.036(0.91)	.038(0.97)	
22GA	.025(0.64)	.030(0.76)	.031(0.79)	
24GA	.020(0.51)	.024(0.61)	.025(0.64)	
26GA	.016(0.41)	.018(0.46)	.019(0.48)	
28GA	.013(0.33)	.015(0.38)	.016(0.41)	



ACCESSORIES — PUNCH AND DIE ADAPTERS

PUNCH ADAPTERS

	L	H	T/mt	Mt
50.430	150	67.00	100	▶

European Precision Style to Wila Trumpf Style

	L	H	T/mt	Mt
50.970	150	80.00	100	▶

Wila Trumpf Style to European Precision Style

	L	H	T/mt	Mt
50.502	200	220.00	90	▶

Wila Trumpf Style to European Precision Style

(WITH TANG PIN)

USE WITH SAFETY CLAMP PLATE 50.499
(CLAMP PLATE INCLUDED WITH 50.502)

	L	H	T/mt	Mt
50.503	200	220.00	90	▶

Wila Trumpf Style to Wila Trumpf Style

DIE ADAPTERS

	L	H	T/mt	Mt
60.910	1000	30.00	100	▶

European Precision Style to Wila Trumpf Style

	L	H	T/mt	Mt
60.920	1000	60.00	100	▶

European Precision Style to Wila Trumpf Style



ACCESSORIES — PUNCH AND DIE EXTENSIONS

PUNCH EXTENSIONS

150 mm

	L	H	T/mt	Mt
50.410	150	100.00	100	

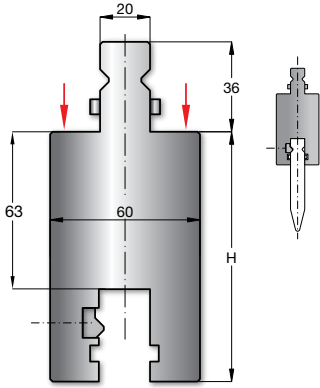

50 mm

	L	H	T/mt	Mt
50.415	50	100.00	100	

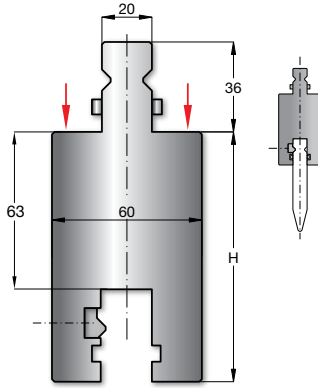

150 mm

	L	H	T/mt	Mt
50.440	150	150.00	100	

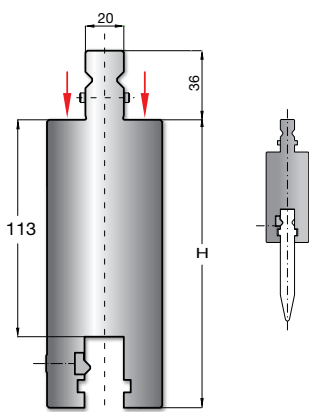

50 mm

	L	H	T/mt	Mt
50.445	50	150.00	100	

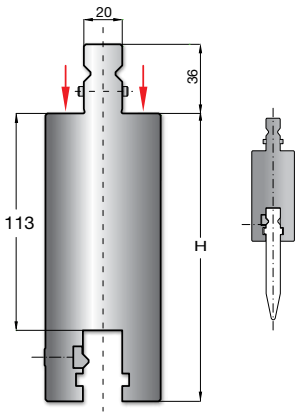

200 mm

	L	H	T/mt	Mt
50.503	200	220.00	90	

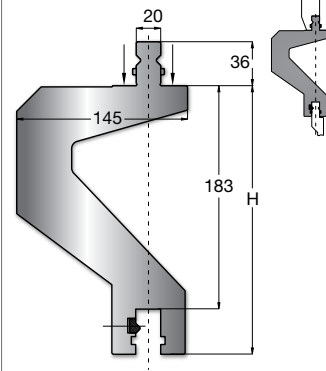

DIE EXTENSION

500 mm

	L	H	T/mt	Mt
60.960S	500	50.00	100	

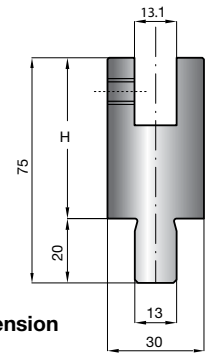

WILA TRUMPF STYLE Extension

ACCESSORIES — PUNCH AND DIE EXTENSIONS



ACCESSORIES — POLYURETHANE FILM AND HOLDERS

ANTI-SCRATCH POLYURETHANE FILM

- Excellent protection against die marks and scratches.
- Economical solution for mar-free bending pre-finished, pre-polished stainless steel, brass, aluminum or pre-painted metal.
- Help protect your dies. Quick setup, universal, saves time and money.

WHITE ANTI-SCRATCH POLYURETHANE FILM

- Standard performance
- White
- Extruded



100 FEET

45.001

Thickness= 0.015 inches
Width= 4 inches
Length= 100 feet

100 FEET

45.002

Thickness= 0.015 inches
Width= 6 inches
Length= 100 feet

100 FEET

45.003

Thickness= 0.030 inches
Width= 4 inches
Length= 100 feet

100 FEET

45.004

Thickness= 0.030 inches
Width= 6 inches
Length= 100 feet

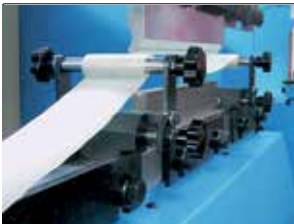

MAGNETIC POLYURETHANE FILM HOLDER

40.850

MAGNETIC ATTACHMENT

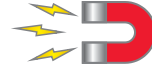

STANDARD POLYURETHANE FILM HOLDER - MECHANICAL

40.800

RAIL ATTACHMENT



ACCESSORIES — REFERENCE SQUARES

SQUARING

For use with long, narrow bends

REFERENCE SQUARES STANDARD

40.660



REFERENCE SQUARES ADJUSTABLE

40.700



ANGLE

For use with angled bends

40.750



40.740



40.745



ACCESSORIES — CLAMP PLATES

CLAMP PLATES FOR ADAPTERS – L=150mm

CLAMP PLATES INCLUDE 2 BOLTS, 2 SPRINGS, 1 CLAMP

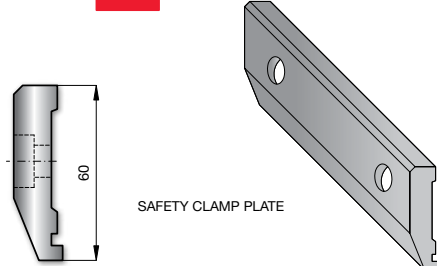
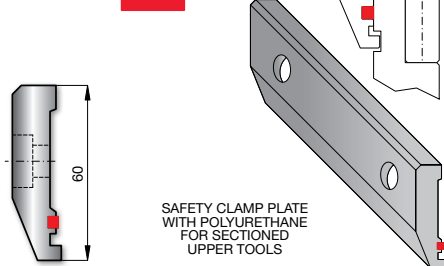
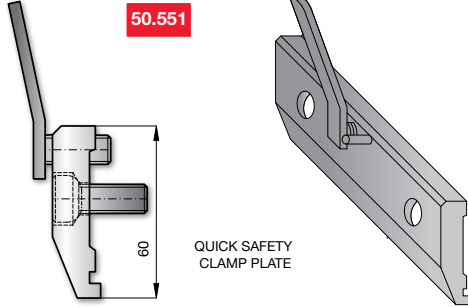
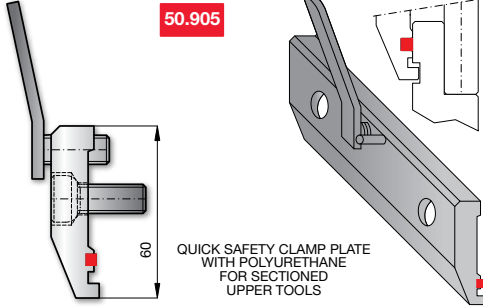
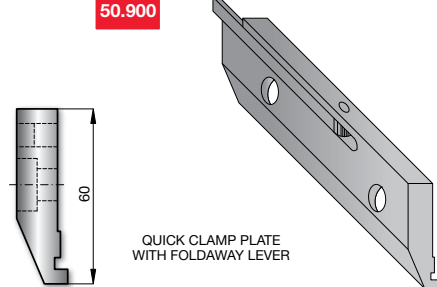
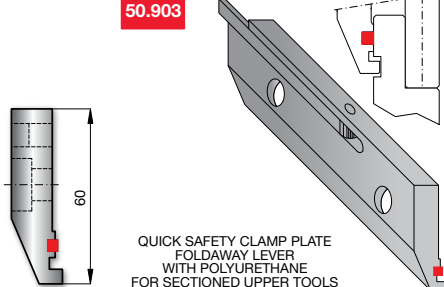
<p>50.571</p>  <p>SAFETY CLAMP PLATE</p>	<p>50.910</p>  <p>SAFETY CLAMP PLATE WITH POLYURETHANE FOR SECTIONED UPPER TOOLS</p>
<p>50.551</p>  <p>QUICK SAFETY CLAMP PLATE</p>	<p>50.905</p>  <p>QUICK SAFETY CLAMP PLATE WITH POLYURETHANE FOR SECTIONED UPPER TOOLS</p>
<p>50.900</p>  <p>QUICK CLAMP PLATE WITH FOLDAWAY LEVER</p>	<p>50.903</p>  <p>QUICK SAFETY CLAMP PLATE FOLDAWAY LEVER WITH POLYURETHANE FOR SECTIONED UPPER TOOLS</p>

EQUIPMENT FOR DOUBLE CLAMPING PLATE – L=150mm

INCLUDES 2 BOLTS, 2 SPRINGS, 1 CLAMP, 2 NUTS

50.577

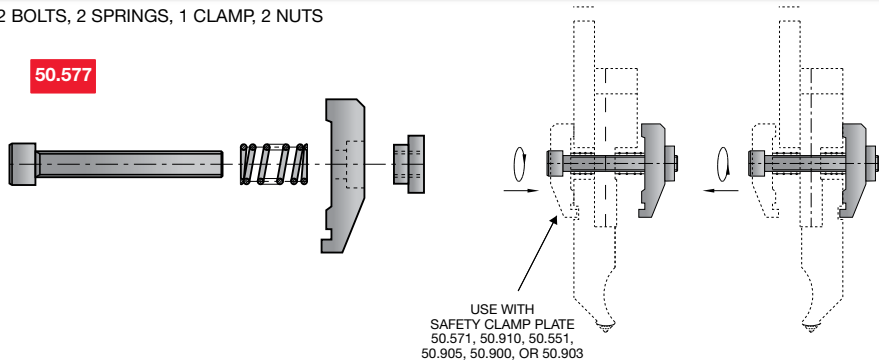

USE WITH SAFETY CLAMP PLATE 50.571, 50.910, 50.551, 50.905, 50.900, OR 50.903

CLAMP QUANTITY GUIDE	
LENGTH	QUANTITY
1000mm	5
2100mm	10
3100mm	15
4100mm	20



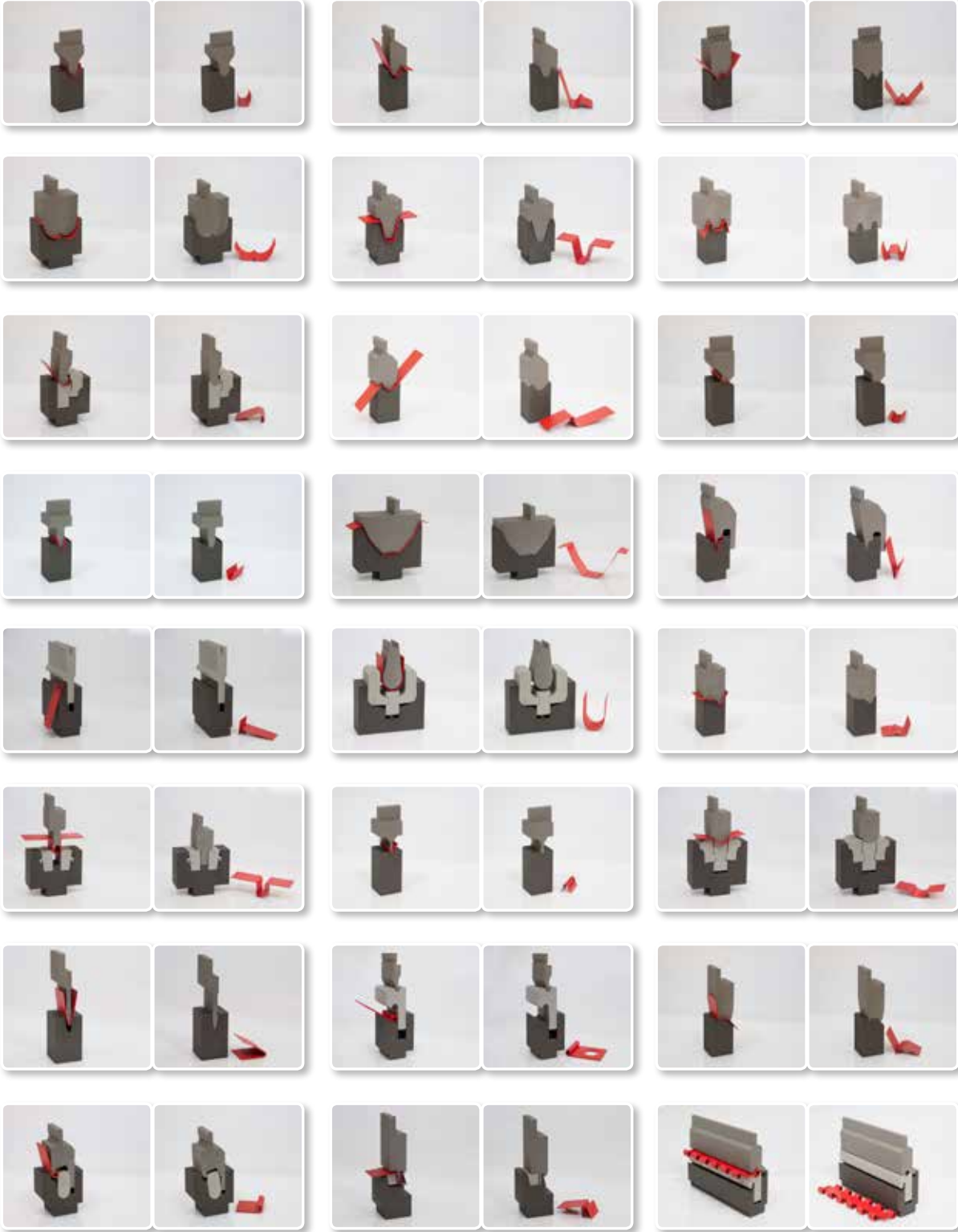



visit mate.com

MATE PRECISION TOOLING

WORLDWIDE HEADQUARTERS:

1295 Lund Boulevard, Anoka, Minnesota 55303 USA
Tel +1.763.421.0230 Fax +1.763.421.0285 mate.com

The Mate Logo is a registered trademark of Mate Precision Tooling Inc.
Amada Promecam is a registered trademark of Amada Europe Corporation.
Trumpf is a registered trademark of Trumpf GMBH & Co.
Wila is a registered trademark of WILA B.V.