

Superior Solutions for Sheet Metal Fabricators

MATE EUROPEAN PRECISION STYLE PRESS BRAKE TOOLING

Amada Promecam Style Press Brake Tooling

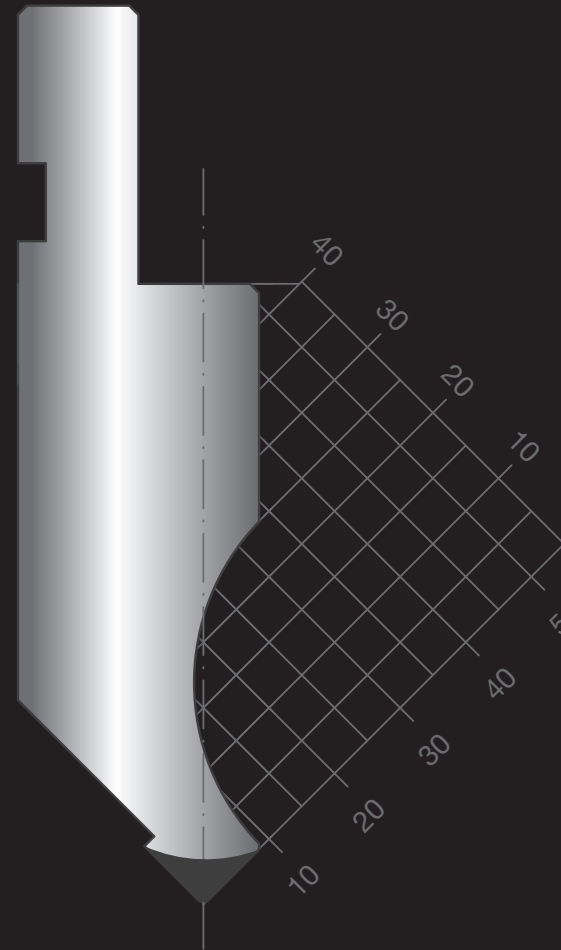

2015
Part Number

WORLDWIDE HEADQUARTERS:

1295 Lund Boulevard, Anoka, Minnesota 55303 USA
Tel +1.763.421.0230 Fax +1.763.421.0285
U.S. Toll Free: Tel 800.328.4492 Fax 800.541.0285
mate.com



MATE PRECISION TOOLING

COMPANY OVERVIEW

Founded in 1962, Mate has grown into a world-class manufacturer of superior products and solutions for sheet metal fabricators. We manufacture tooling for every major CNC punch press, supply and support a wide variety of precision ground press brake tooling, and offer a complete line of CO2 and fiber laser products. Our mission: To be the world's leading supplier of precision tooling for CNC punch presses. Our purpose: Helping sheet metal fabricators produce quality parts faster and more efficiently.



Headquartered in Anoka, Minnesota, in a 300,000 sq. ft. (28,000m²) state-of-the-art facility.

COMMITMENT TO QUALITY

Mate's dedication to quality is not just demonstrated in the products and services we provide, it is a part of every aspect of our business. This commitment was formally recognized when Mate was honored with the Minnesota Quality Award, Achievement level, for 2005. We integrate the Baldrige National Quality Program's criteria into the way we operate and continually measure our progress in improving our products, processes, and service.



CUSTOMER SATISFACTION GUARANTEED

Customer service is a critical component of Mate's business. Mate's sales engineers are experts in their field working on site with customers to solve fabricating issues. This commitment to customer satisfaction is extended around the world with Mate tooling experts available in every industrialized country. Customer education is available for every product Mate offers and is available 24/7 at mate.com. [My.mate.com](http://my.mate.com), a free web-based portal, allows registered users access to previously ordered drawings of special shapes and assemblies. Mate offers an extensive standard product line that can be delivered with same day or next day service and all our products come with a 100% satisfaction guarantee.

PRODUCTS AND SOLUTIONS THAT WORK

Mate's product engineering team currently holds several national and international patents and continues to develop products that push the boundaries of manufacturing technology. Our state-of-the-art customer solution center is an integral part of this process. It allows us to develop and test new tooling concepts and designs, and focus on proving the viability of value-added products while reducing the time needed to bring these products to market. The customer solution center also allows us to replicate the end user's environment and needs in every way. We work closely with the world's leading sheet metal fabricators and punch press manufacturers conducting research and evaluating new products. These partnerships bring to Mate a combined effort to continually offer customers superior products with proven solutions.

SPANNING THE GLOBE

Mate has over 80 dealers providing products and services in every industrialized country. Our dealers are thoroughly trained to assist with all tooling needs from simple hole punching to complex special applications. Mate recognized the need for an international specialist in the punch press tooling field and has been serving the international market since 1967. Our commitment to serving manufacturers around the world was formally recognized when Mate was presented with the President's "E" Certificate for Exports by the Secretary of Commerce in 1996. Today, more than 50% percent of Mate's revenue has come from outside the United States. We are committed to improving manufacturing technology around the world by helping established and emerging manufacturers produce quality parts faster and more efficiently.



TABLE OF CONTENTS AND MATERIAL SPECIFICATIONS

European Precision Style Press Brake Tooling

Bending Basics	4
----------------	---

European Precision Style Punches

Punch Overview	5
Punches	6-19
Rotary Punch	20
Moving Horns	21
Z Offset Tool Holders	22
Z Offset Tool Inserts	23
Holders for Reversible Two-Sided Radius Inserts	24
Radius Inserts	25
Holders for Radius/Flat Inserts	26
Radius/Flat Inserts	27
Holders and Polyurethane Inserts	28

European Precision Style Dies

Die Overview	29
Bolt-On Style 2V Dies	30-31

Self-Centering 2V Dies	32-33
Multi-V Dies	34
1V Dies	35-37
Pillar Dies H80	38-39
Pillar Dies H120	40-41
Die Inserts	42
Die Inserts Holder	43
Nylon Insert Holders	44
Nylon Inserts	45
Hemming Tools	46-47



Accessories for Press Brakes

Polyurethane Film and Holders	48
Reference Squares	49
Punch Adapters	50
Clamp Plates	51
Swing™ Clamps and Die Extensions	52

Reference Guides

Conversion Calculator	53
Solution Gallery Images	54-55

Catalog Key:



Material Type	Base Material	Base/Core Hardness	Wear Surfaces Induction Hardened	Depth of Induction Hardness	Application	Tonnage limits
Gray 	C45	20-24 HRC	58-60 HRC	3-4mm (0.118-0.158)	Most common tool profiles, high force capable	50 to 100 tons/meter (17 to 34 tons/ft)
Red 	C45	20-24 HRC	58-60 HRC	3-4mm (0.118-0.158)	Tool profiles having thinner or taller cross sections	35 to 70 tons/meter (12 to 24 tons/ft)
Yellow 	42 CrMo4	20-24 HRC	58-60 HRC	3-4mm (0.118-0.158)	Tool profiles having thin cross sections	15 to 60 tons/meter (5 to 20 tons/ft)

HOW TO READ A MATE® PART NUMBER

Example: **012.345S**

The numerical component identifies the tool profile. A profile is the image of a tool as shown in the catalog. The character component is used to identify the length of the tool.

The character component code is:

	M	Half Length
	S	Full Length
	F	Segmented Length

A number inside the arrow identifies the actual length of the tool in millimeters.

For example: **415 mm** 



BENDING BASICS

METRIC AIR BENDING CHART FORCE REQUIRED FOR 90° AIR BENDING, SHEET RESISTANCE R=45 kg/mm²

T	6	8	10	12	16	20	25	32	40	50	63	80	100	125	160	200	250
	4	5.5	7	8.5	11	14	17.5	22	28	35	45	55	71	89	113	140	175
	1	1.3	1.6	2	2.6	3.3	4	5	6.5	8	10	13	16	20	26	33	41
0.5	3																
0.6	4																
0.8	7	5	4														
1	11	8	7	6													
1.2	16	12	10	8	6												
1.5	17		15	13	9	8											
2	27			22	17	13	11										
2.5	35				26	21	17	13									
3	38					30	24	19	15								
4	54						42	34	27	21							
5	67							52	42	33	26						
6	75								60	48	38	30					
8	107									85	68	53	43				
10	134										105	85	67	53			
12	153											120	96	78	60		
15	188												150	120	95	75	
20	270													215	170	135	108

- Force in ton/meter **F**
- Thickness of material in mm **T**
- V-opening **V**
- Sheet Resistance **R**
- Inside radius **ir**
- Minimum flange length **b**

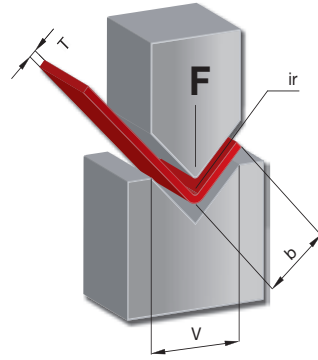

CALCULATION OF FORCE FOR AIR BENDING

$$F = \frac{T^2 \times 2 \times R}{1.4 \times V} = \dots \text{ Tons/mt}$$

R	
Aluminum	R=20-25 kg/mm ²
Mild steel	R=40-45 kg/mm ²
Stainless steel	R=65-70 kg/mm ²

TYPE OF BENDING	V- Width	Inside Radius	Springback	Bending precision	FEATURES
Air Bending	12T-15T	2T-2.5T	ABOUT +/- 45'	FORMS SURFACE with large radius	Low force requirement Greater springback
Bottoming	6T-12T	1T-2T	ABOUT +/- 30'	GOOD	Low force requirement Good precision
Coining	5T	0.5T-0.8T	ABOUT +/- 15'	GOOD	High force requirement 5-8 times greater than bottoming

SHEET THICKNESS (mm)	0.5 - 2.5	2.5 - 8	8 - 10	10 OR MORE
V - width (mm)	6 T	8 T	10 T	12 T

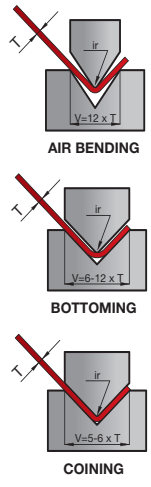

PUNCH LENGTHS

PUNCHES ARE AVAILABLE IN THE FOLLOWING STANDARD LENGTHS:

HALF LENGTH - (M)

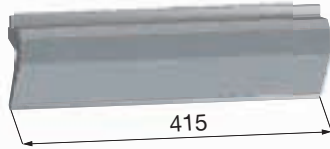

415 mm

STANDARD LENGTH - (S)

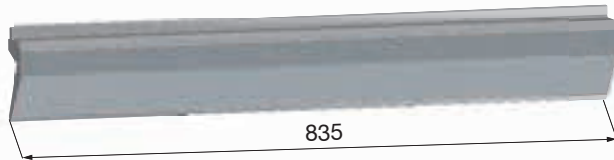

835 mm

SECTIONED LENGTH - (F)

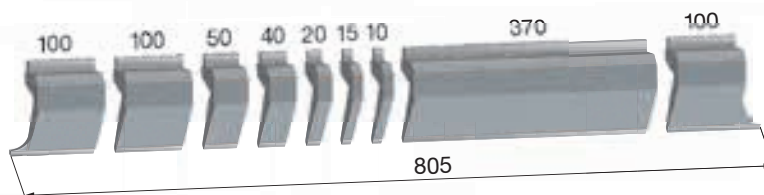

805 mm

HORNS SCHEME STANDARD SECTIONING (NUMBER INDICATES PUNCH PROFILE)

10.142	10.175	10.505	11.106	11.228	11.275	11.857
10.143	10.176	10.506	11.107	11.230	11.650	11.858
10.152	10.261	10.510	11.108	11.231	11.660	11.861
10.153	10.262	10.516	11.145	11.232	11.670	11.863
10.154	10.263	10.517	11.146	11.233	11.800	11.864
10.155	10.264	10.520	11.147	11.240	11.835	11.865
10.156	10.500	10.626	11.148	11.241	11.840	11.866
10.157	10.501	10.672	11.149	11.256	11.848	11.867
10.170	10.502	11.100	11.151	11.257	11.849	11.868
10.173	10.503	11.101	11.200	11.259	11.853	11.869
10.174	10.504	11.105	11.201	11.260	11.855	11.870

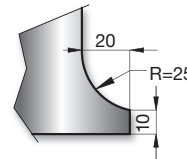

HORNS SCHEME STANDARD SECTIONING (NUMBER INDICATES PUNCH PROFILE)

10.136	10.514	11.104	11.514	11.600	11.780	11.880
10.150	10.515	11.134	11.528	11.710	11.810	
10.511	11.102	11.158	11.530	11.720	11.820	
10.512	11.103	11.258	11.540	11.750	11.830	

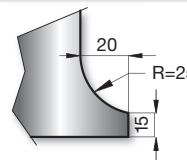

PUNCHES

SAFETY GROOVE DATA

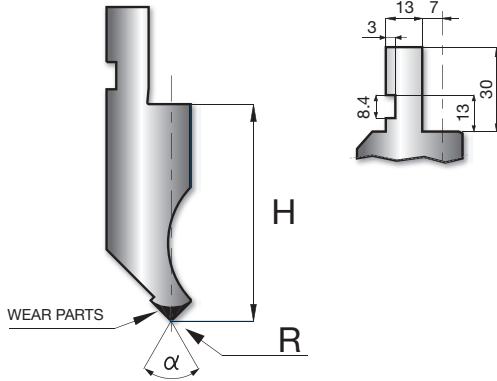

Legend	
H	= Height
α	= Degree
R	= Radius

415 mm

835 mm

805 mm

α R H T/mt Mt

11.100	90°	0.80	66.60	100	▶
10.152	90°	0.25	66.60	100	▶
11.101	88°	3.00	65.45	100	▶
11.145	88°	0.80	66.50	100	▶
10.153	88°	0.25	66.50	100	▶
11.201	85°	3.00	65.45	100	▶
11.200	85°	0.80	66.50	100	▶
11.853	85°	0.25	66.50	100	▶
11.275	75°	0.80	67.60	100	▶

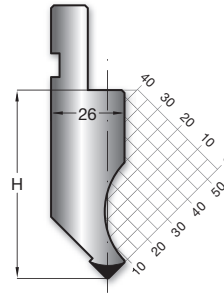

90°

88°

85°

75°

415 mm

835 mm

805 mm

α R H T/mt Mt

10.175	90°	0.60	66.75	35	▶
10.173	90°	0.25	66.70	35	▶
10.176	88°	0.60	66.74	35	▶
10.174	88°	0.25	66.70	35	▶
10.170	85°	0.60	66.74	35	▶
11.857	85°	0.25	67.00	35	▶

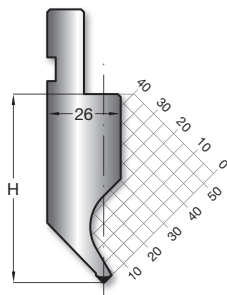

90°

88°

85°

415 mm

835 mm

805 mm

α R H T/mt Mt

11.870	88°	0.80	135.00	100	▶
11.232	85°	0.80	135.00	100	▶

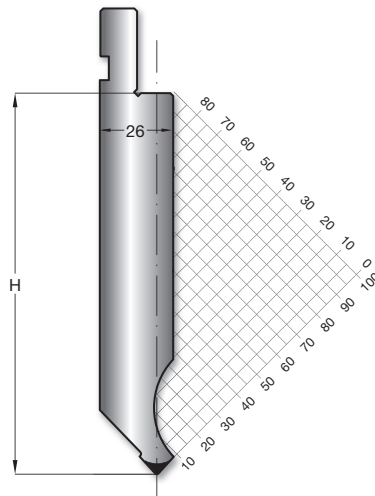

88°

85°



PUNCHES

415 mm
835 mm
805 mm

	α	R	H	T/mt	Mt
11.228	88°	0.80	105.00	100	▶
11.231	85°	3.00	105.00	100	▶
11.230	85°	0.80	105.00	100	▶

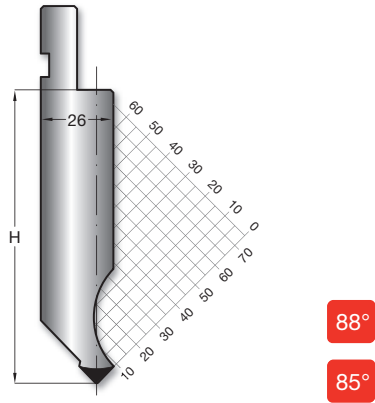

415 mm
835 mm
805 mm

	α	R	H	T/mt	Mt
10.261	90°	0.60	100.00	50	▶
10.263	90°	0.25	100.00	50	▶
10.262	88°	0.60	100.00	50	▶
10.264	88°	0.25	100.00	50	▶
10.626	85°	0.25	100.00	50	▶
11.861	85°	0.60	100.00	50	▶

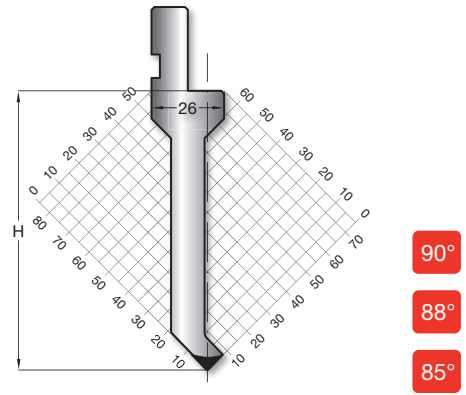

415 mm
835 mm
805 mm

	α	R	H	T/mt	Mt
11.858	88°	0.60	135.00	40	▶
11.855	85°	0.60	135.00	40	▶

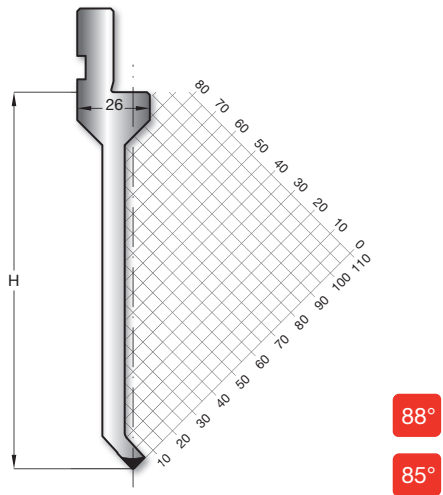

415 mm
835 mm
805 mm

	α	R	H	T/mt	Mt
11.259	90°	0.60	95.00	50	▶
11.256	90°	0.25	95.00	50	▶
11.260	88°	0.60	95.00	50	▶
11.257	88°	0.25	95.00	50	▶

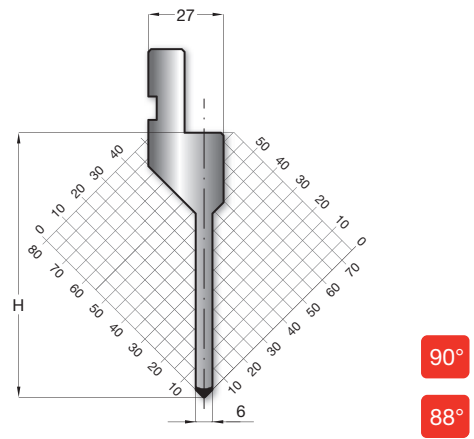

PUNCHES

415 mm
835 mm
805 mm

α R H T/mt Mt

10.503	90°	0.20	104.70	50	▶
10.504	88°	0.80	104.50	50	▶
11.650	85°	0.80	104.50	50	▶
11.868	85°	0.25	104.70	50	▶

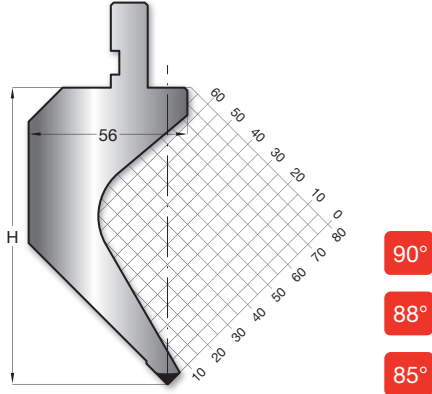

415 mm
835 mm
805 mm

α R H T/mt Mt

10.501	90°	0.20	90.00	50	▶
10.502	88°	0.80	89.70	50	▶
11.865	85°	0.80	89.70	50	▶
10.672	85°	0.25	90.00	50	▶

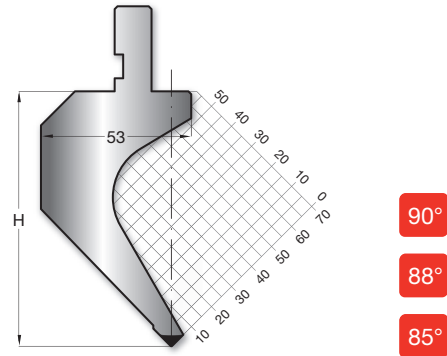

415 mm
835 mm
805 mm

α R H T/mt Mt

11.107	90°	0.80	104.50	50	▶
10.156	90°	0.25	104.50	50	▶
11.108	88°	3.00	103.50	50	▶
11.147	88°	0.80	104.50	50	▶
10.157	88°	0.25	104.50	50	▶
11.867	85°	0.25	104.50	50	▶
11.866	85°	3.00	103.50	50	▶
11.151	85°	0.80	104.50	50	▶

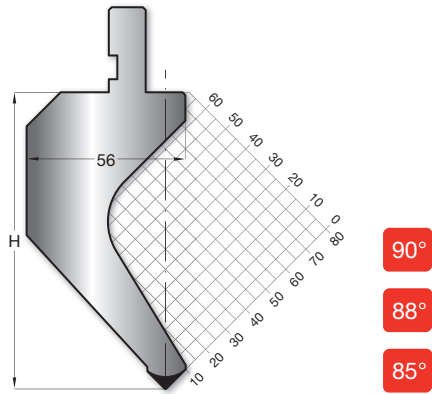

415 mm
835 mm
805 mm

α R H T/mt Mt

11.105	90°	0.80	89.60	60	▶
10.154	90°	0.25	89.60	60	▶
11.106	88°	3.00	88.50	60	▶
11.146	88°	0.80	89.58	60	▶
10.155	88°	0.25	89.60	60	▶
11.660	85°	0.80	89.58	60	▶
11.863	85°	3.00	88.50	60	▶
11.864	85°	0.25	89.70	60	▶

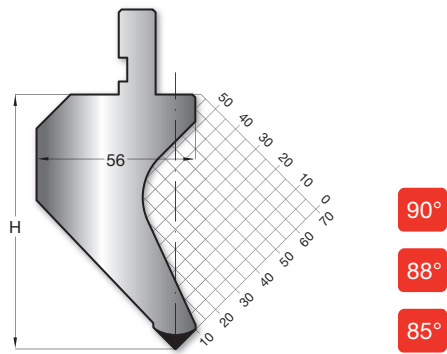

PUNCHES

505 mm
500 mm

α	R	H	T/mt	Mt
11.840	85°	1.00	185.00	60

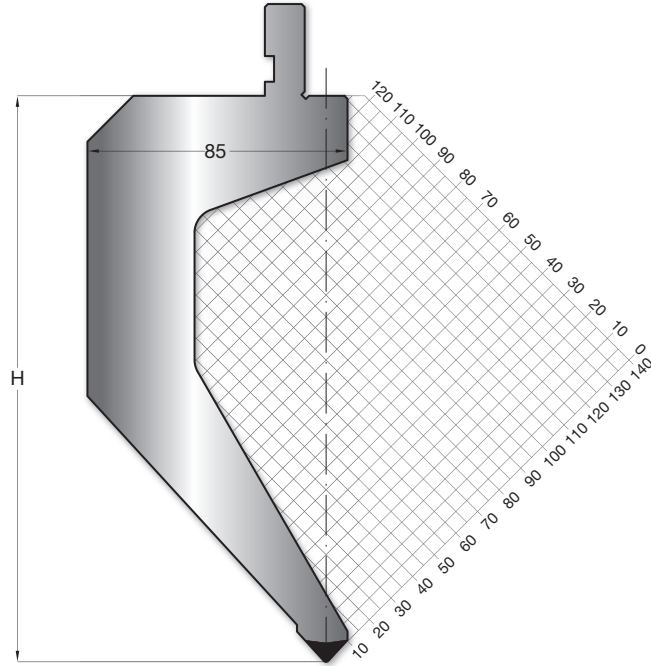

STANDARD LENGTH - (S)

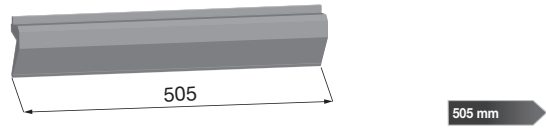

HORNS SCHEME STANDARD SECTIONING

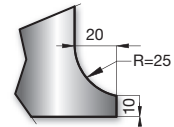

SECTIONED LENGTH - (F)

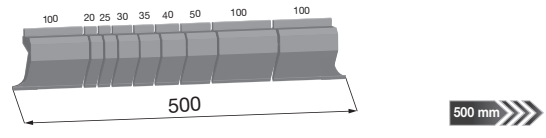

85°



PUNCHES

505 mm
500 mm

α R H T/mt Mt

11.800 85° 1.00 200.00 70

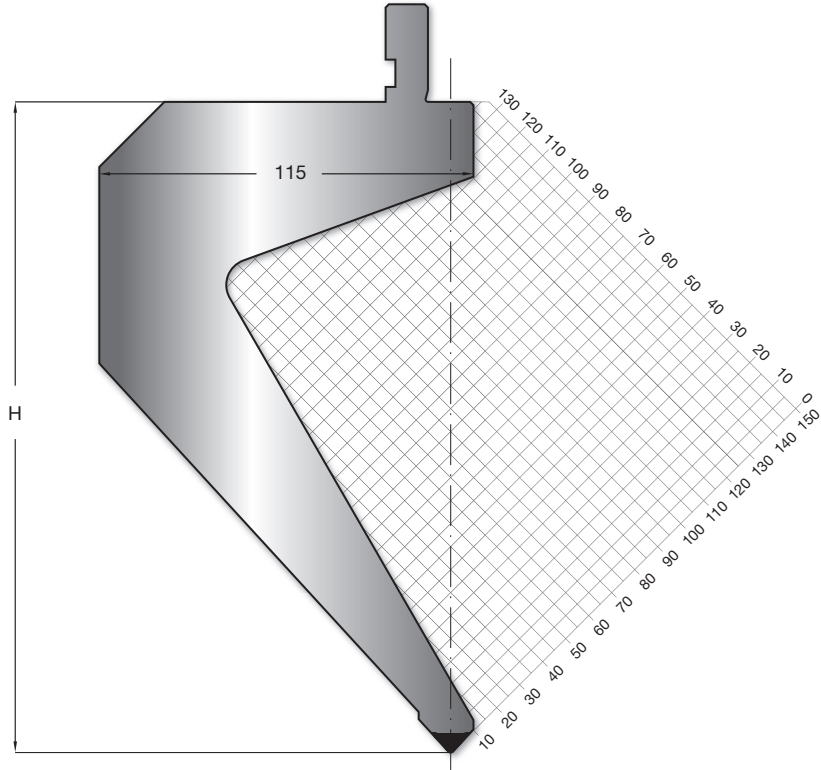

STANDARD LENGTH - (S)

HORNS SCHEME STANDARD SECTIONING

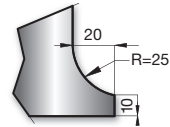
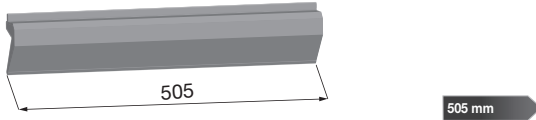

SECTIONED LENGTH - (F)

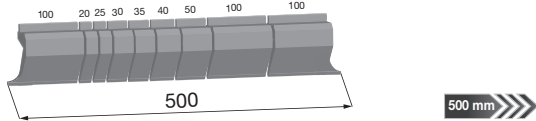

85°



PUNCHES

415 mm
835 mm
805 mm

	α	R	H	T/mt	Mt
10.150	90°	0.60	84.13	20	▶
10.512	88°	0.60	84.13	20	▶

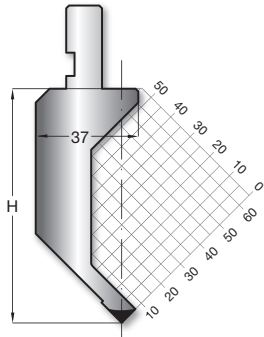

90°
88°

415 mm
835 mm
805 mm

	α	R	H	T/mt	Mt
10.505	88°	0.80	120.00	50	▶
11.835	85°	0.80	120.00	50	▶

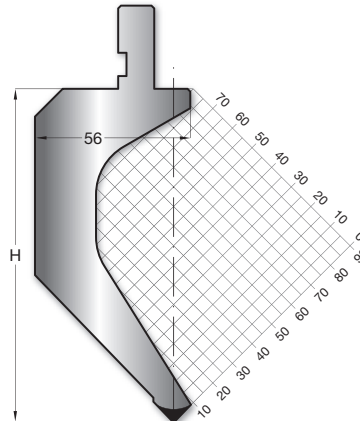

88°
85°

415 mm
835 mm
805 mm

	α	R	H	T/mt	Mt
11.670	85°	0.80	145.00	60	▶

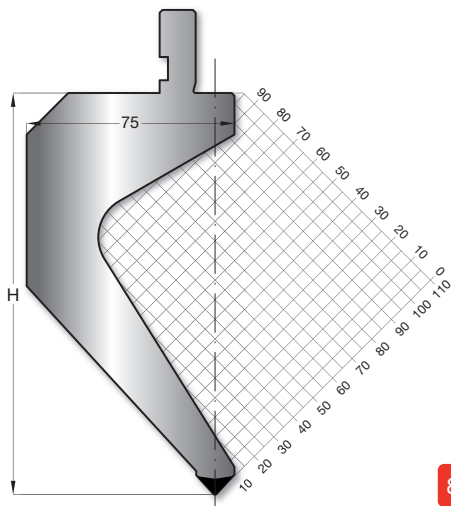

85°



PUNCHES

PUNCHES

415 mm

835 mm

805 mm

α R H T/mt Mt

11.149	88°	0.80	165.00	60	▶
11.849	85°	0.80	165.00	60	▶

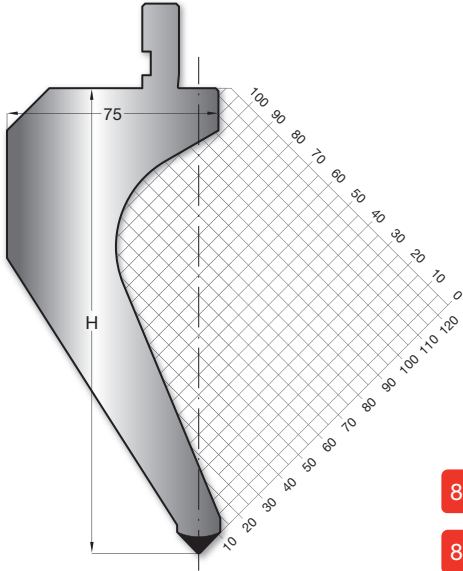

88°

85°

415 mm

835 mm

805 mm

α R H T/mt Mt

11.148	88°	0.80	145.00	70	▶
11.848	85°	0.80	145.00	70	▶

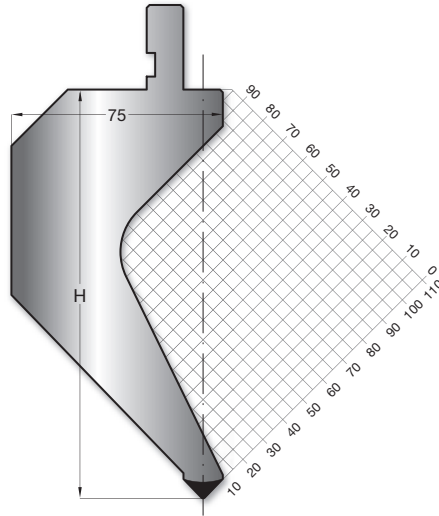

88°

85°



415 mm
835 mm
805 mm

11.830 α R H T/mt Mt

88° 0.60 85.00 15

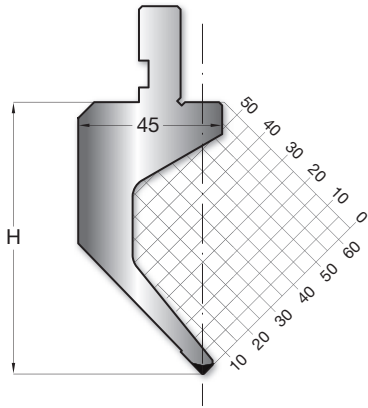

88°

415 mm
835 mm
805 mm

11.820 α R H T/mt Mt

85° 0.60 115.00 20

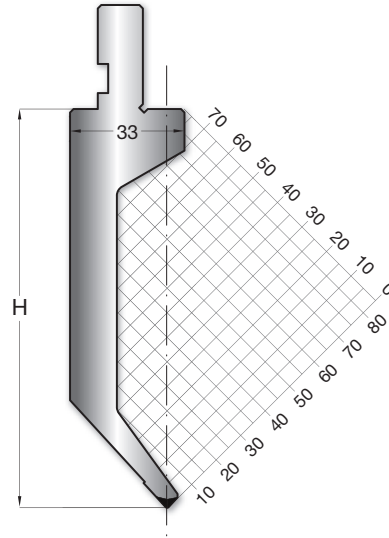

85°

415 mm
835 mm
805 mm

10.520 α R H T/mt Mt

60° 0.80 115.00 50

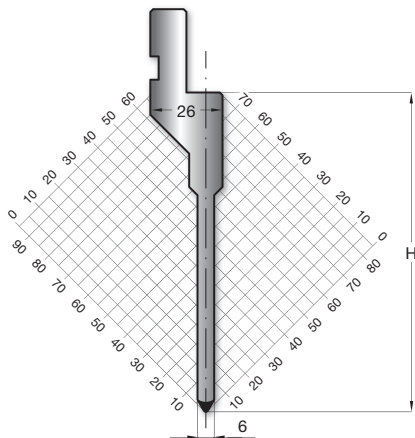

60°

415 mm
835 mm
805 mm

10.510 α R H T/mt Mt

60° 0.80 115.00 60

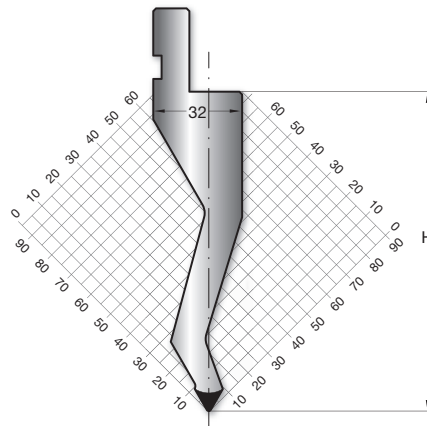

60°



PUNCHES

415 mm
835 mm
805 mm

α	R	H	T/mt	Mt
10.506	60°	0.80	130.00	40

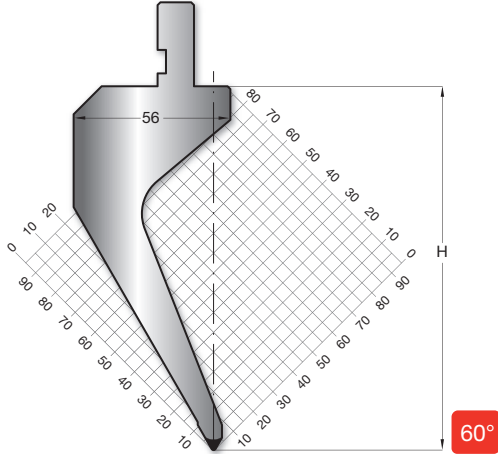

415 mm
835 mm
805 mm

α	R	H	T/mt	Mt
10.500	60°	0.80	115.00	40

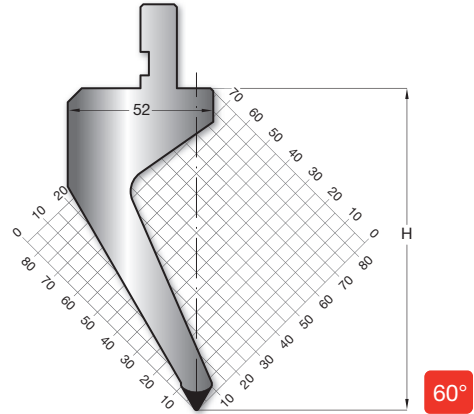

415 mm
835 mm
805 mm

α	R	H	T/mt	Mt
10.516	60°	0.80	85.00	40

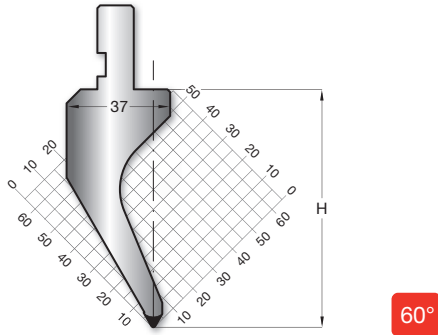

415 mm
835 mm
805 mm

α	R	H	T/mt	Mt
10.143	60°	2.00	65.80	60
10.142	60°	0.80	67.00	60

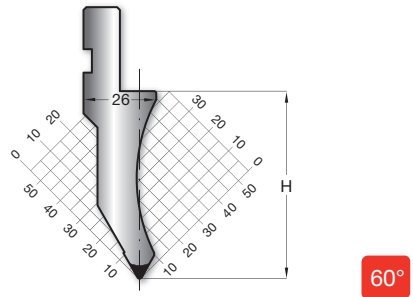

415 mm
835 mm
805 mm

	α	R	H	T/mt	Mt
10.517	60°	0.80	80.00	25	

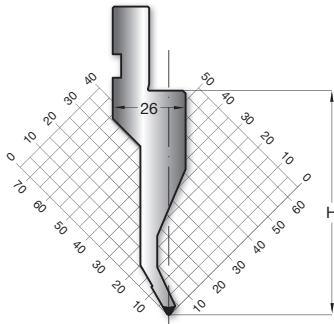

60°

415 mm
835 mm
805 mm

	α	R	H	T/mt	Mt
10.136	60°	6.00	65.00	100	

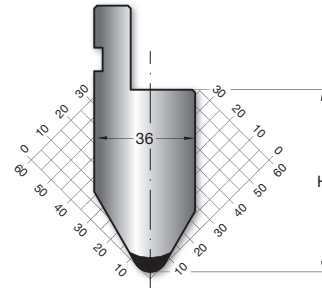

60°

415 mm
835 mm
805 mm

	α	R	H	T/mt	Mt
11.710	60°	5.00	115.00	100	

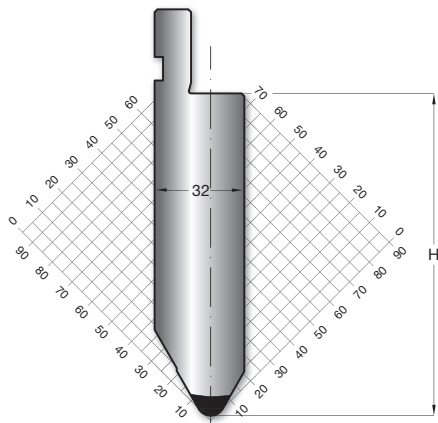

60°

415 mm
835 mm
805 mm

	α	R	H	T/mt	Mt
11.720	60°	10.00	115.00	100	

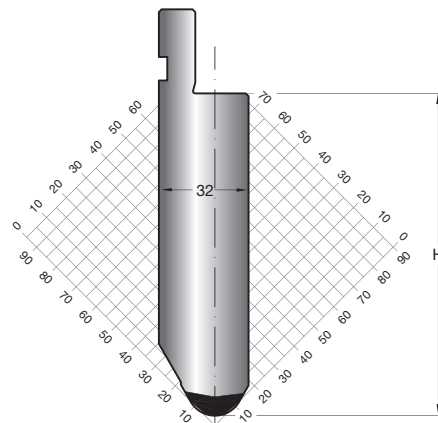

60°



PUNCHES

415 mm

835 mm

805 mm

	α	R	H	T/mt	Mt
11.750	60°	0.80	135.00	70	▶

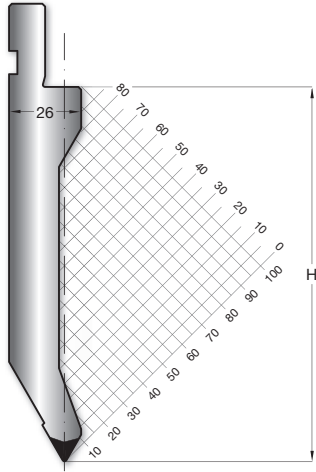

60°

415 mm

835 mm

805 mm

	α	R	H	T/mt	Mt
11.134	45°	0.60	66.30	80	▶
11.102	45°	1.00	65.20	80	▶

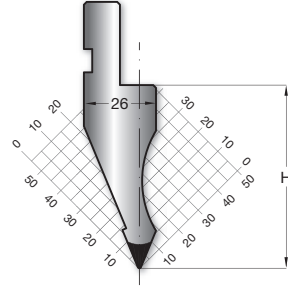

45°

415 mm

835 mm

805 mm

	α	R	H	T/mt	Mt
11.104	35°	1.50	86.00	70	▶
11.600	35°	0.80	90.00	70	▶
11.103	35°	0.60	86.00	70	▶

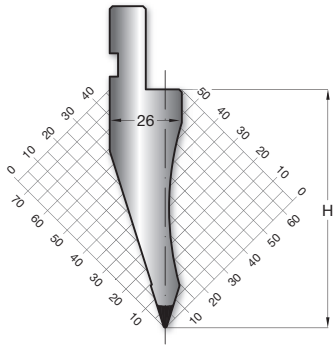

35°

415 mm

835 mm

805 mm

	α	R	H	T/mt	Mt
10.514	30°	0.60	80.00	50	▶

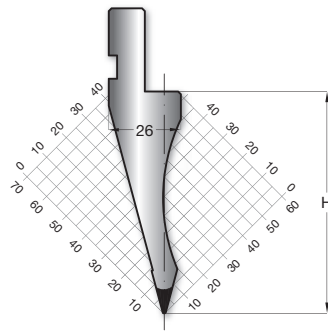

30°



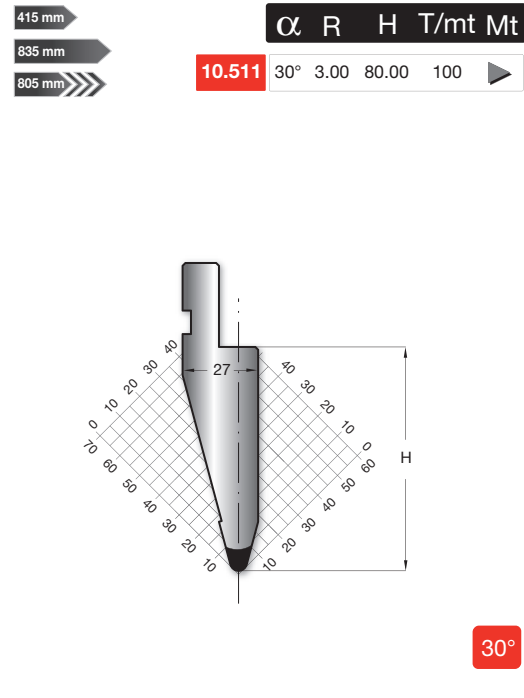
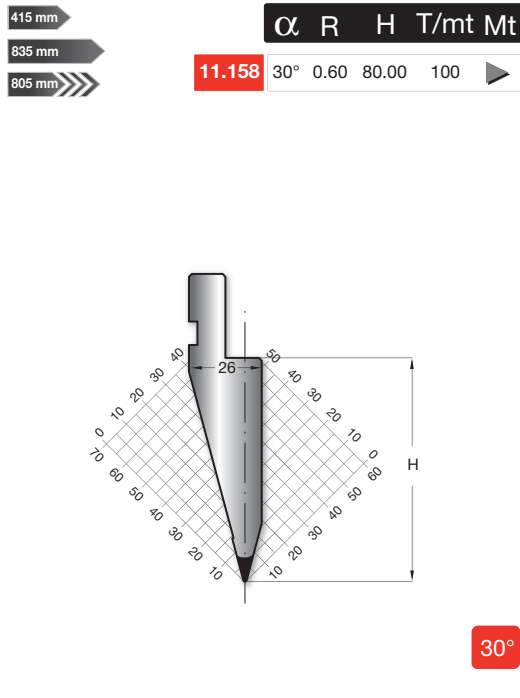
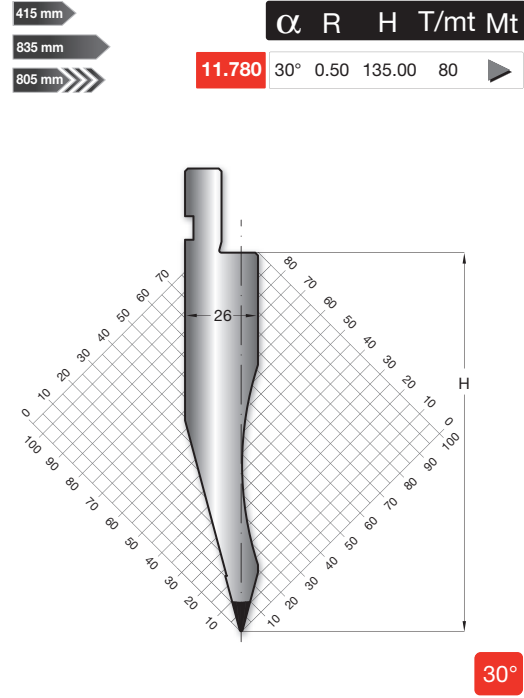
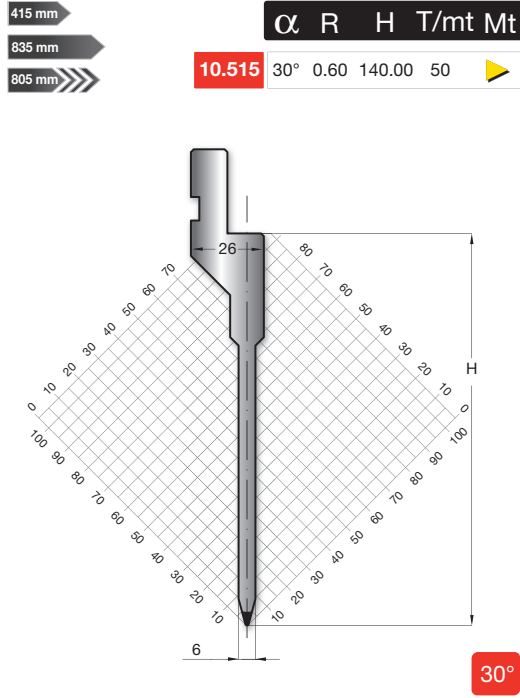

PUNCHES

PUNCHES

415 mm

835 mm

805 mm

α R H T/mt Mt

11.810 30° 1.00 200.00 50 ▶

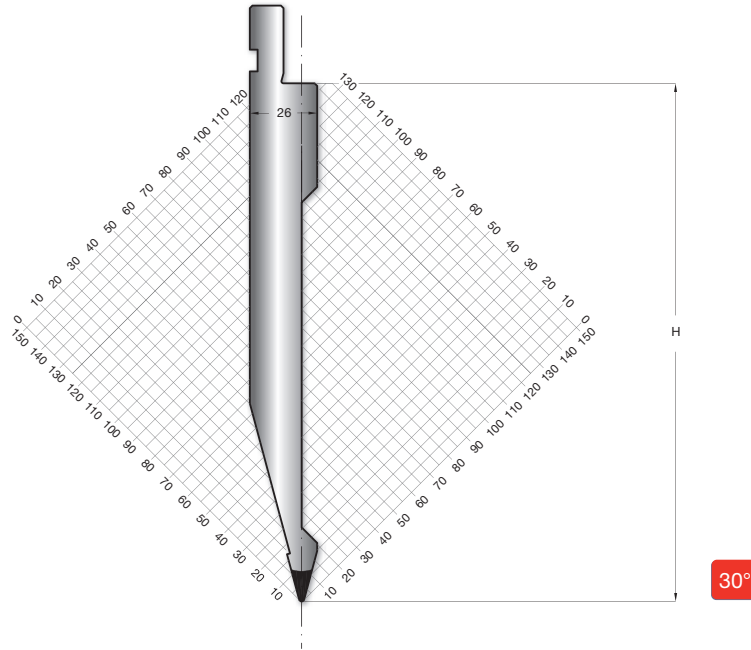

415 mm

835 mm

805 mm

α R H T/mt Mt

11.880 30° 0.80 150.00 40 ▶

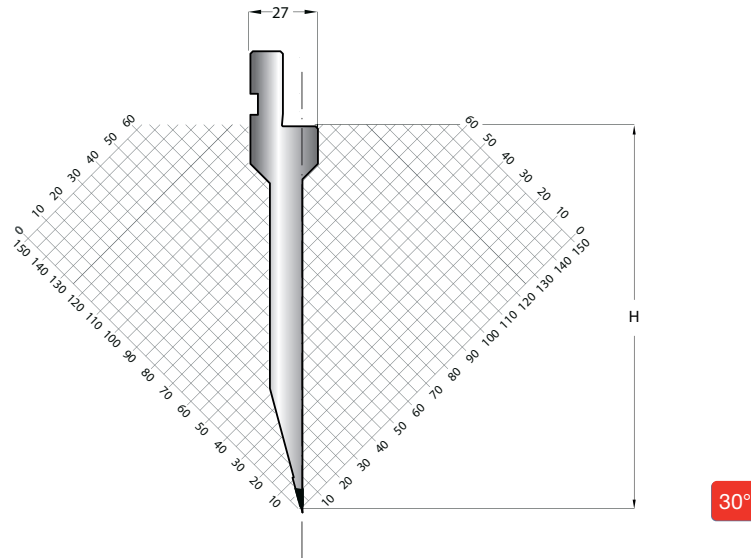

415 mm
835 mm
805 mm

α	R	H	T/mt	Mt
11.258	30°	0.60	104.00	100

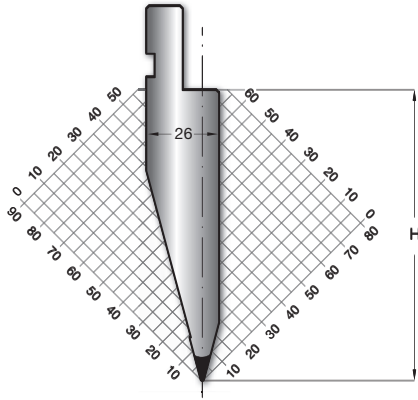

30°

415 mm
835 mm
805 mm

α	R	H	T/mt	Mt
11.530	30°	5.00	104.00	100
11.528	30°	3.00	104.00	100

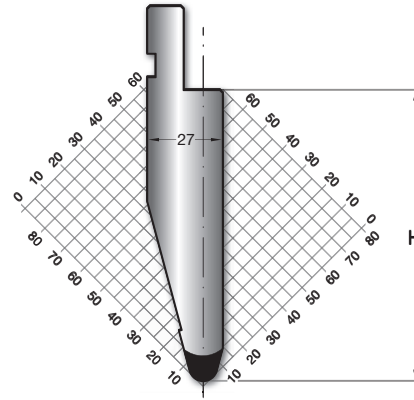

30°

415 mm
835 mm
805 mm

α	R	H	T/mt	Mt
11.514	30°	0.60	104.00	50

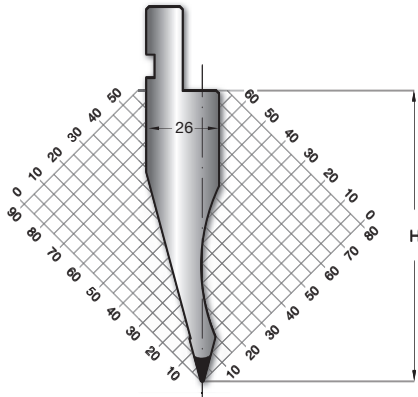

30°

415 mm
835 mm
805 mm

α	R	H	T/mt	Mt
11.540	26°	0.80	117.00	100

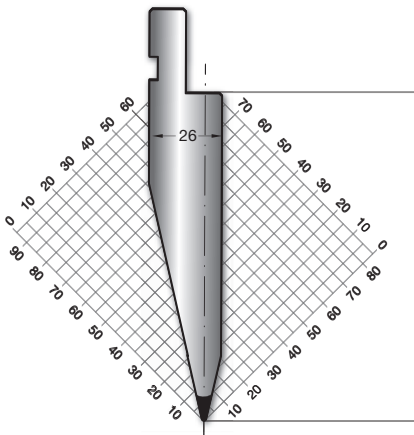

26°



ROTARY PUNCH

ROTARY PUNCH

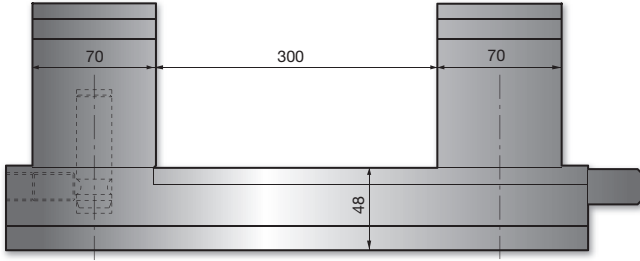

	α	R	H	T/mt	Mt
40.670	88°	0.80	110.00	15	▶
40.680	85°	0.80	110.00	15	▶

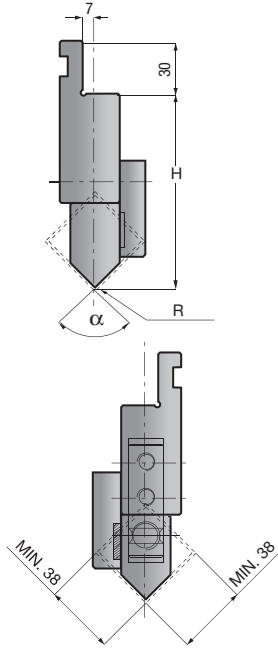

85° 88°

DESCRIPTION



MOVING HORNS

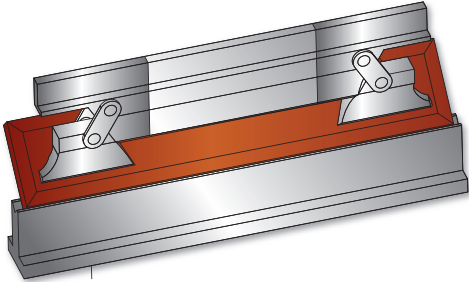
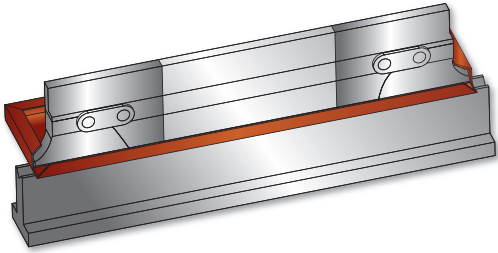

MOVING HORNS CODE

40.110
40.111
40.112
40.113
40.114
40.115
40.116
40.120
40.121
40.122
40.123
40.124

PUNCH CODE

(SEE PAGE 6
FOR MATCHING
PUNCH PROFILES
AND PRICES)

10.152
10.153
11.100
11.145
11.200
11.101
11.201
10.175
10.176
10.170
10.173
10.174

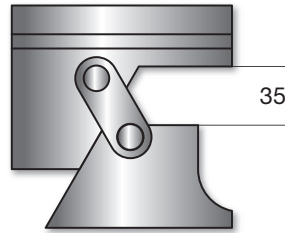
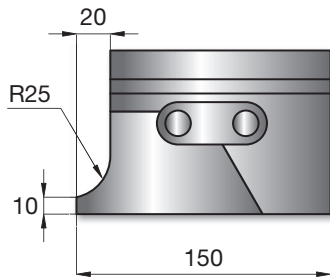

DESCRIPTION



Z OFFSET TOOL HOLDERS

415 mm

835 mm

T/mt Mt

40.419

100

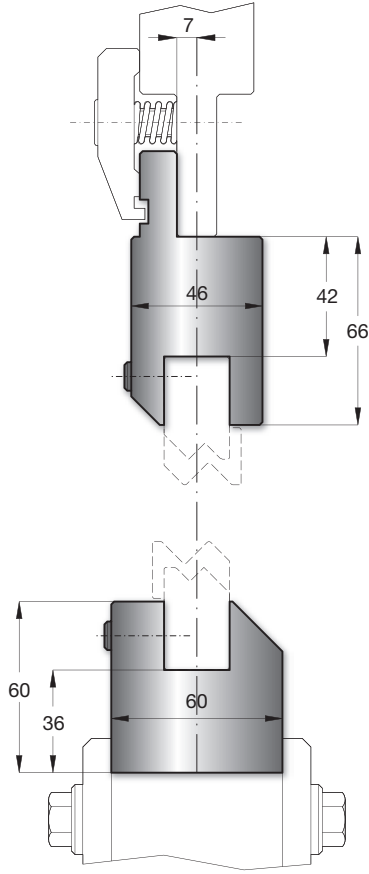

ASSEMBLY SCHEME

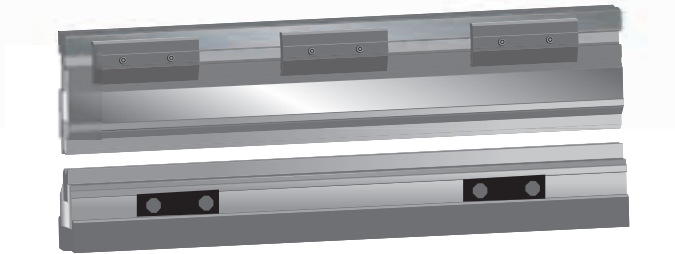

Z OFFSET TOOL INSERTS

415 mm
835 mm

Z α T* T/mt Mt

40.510	1.00	160°	1,0mm	100	▶
40.515	1.50	160°	1,2mm	100	▶
40.520	2.00	150°	1,5mm	100	▶
40.525	2.50	140°	1,5mm	100	▶

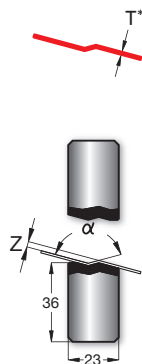

160°
150°
140°

415 mm
835 mm

Z α T* T/mt Mt

40.511	1.00	90°	0,5mm	100	▶
40.516	1.50	90°	0,5mm	100	▶
40.521	2.00	90°	0,5mm	100	▶
40.526	2.50	90°	0,8mm	100	▶
40.530	3.00	90°	1,0mm	100	▶
40.535	3.50	90°	1,0mm	100	▶
40.540	4.00	90°	1,2mm	100	▶
40.545	4.50	90°	1,5mm	100	▶
40.550	5.00	90°	1,5mm	100	▶
40.555	5.50	90°	1,5mm	100	▶
40.560	6.00	90°	1,5mm	100	▶
40.565	6.50	90°	1,5mm	100	▶
40.570	7.00	90°	1,5mm	100	▶
40.575	7.50	90°	1,6mm	100	▶
40.580	8.00	90°	1,6mm	100	▶

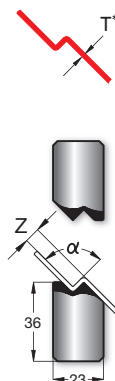

90°

415 mm
835 mm

Z α T* T/mt Mt

40.590	9.00	90°	2,0mm	100	▶
40.610	10.00	90°	2,0mm	100	▶
40.611	11.00	90°	2,0mm	100	▶
40.612	12.00	90°	2,0mm	100	▶

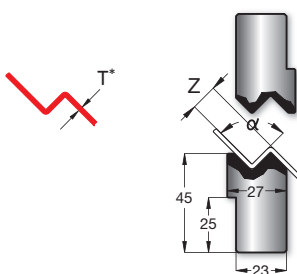

90°

415 mm
835 mm

Z α T* T/mt Mt

40.613	13.00	90°	2,5mm	100	▶
40.614	14.00	90°	2,5mm	100	▶
40.615	15.00	90°	3,0mm	100	▶

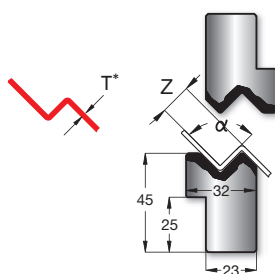

90°

415 mm
835 mm

T/mt Mt

40.500	100	▶
--------	-----	---



Flattening Insert

* MAXIMUM MATERIAL THICKNESS



HOLDERS FOR REVERSIBLE TWO-SIDED RADIUS INSERTS

HOLDERS FOR REVERSIBLE TWO-SIDED RADIUS INSERTS

412 mm
830 mm

T/mt Mt

10.180 100 ▶

HALF LENGTH - (M)



STANDARD LENGTH - (S)

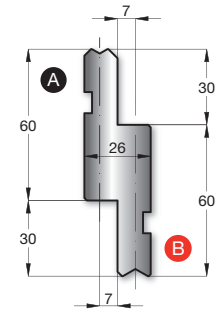
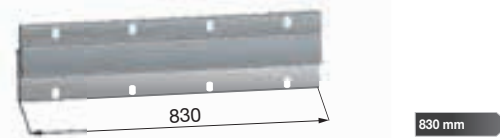

ASSEMBLY SCHEME

The inserts are mounted on A or B side depending on the type of radius. See page 25.

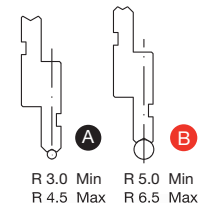

INSERTS

415 mm → 835 mm

R Side

10.181	3.00	A
10.182	3.50	A
10.183	4.00	A
10.184	4.50	A
10.185	5.00	B
10.186	5.50	B
10.187	6.00	B
10.188	6.50	B

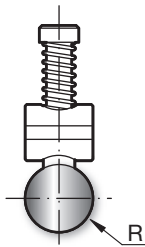

Radius insert sold with bolt assembly.

HALF LENGTH - (M)

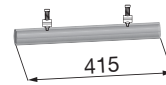

415 mm

STANDARD LENGTH - (S)

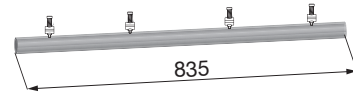

835 mm

BOLT ASSEMBLY

40.003

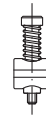

ASSEMBLY SCHEME

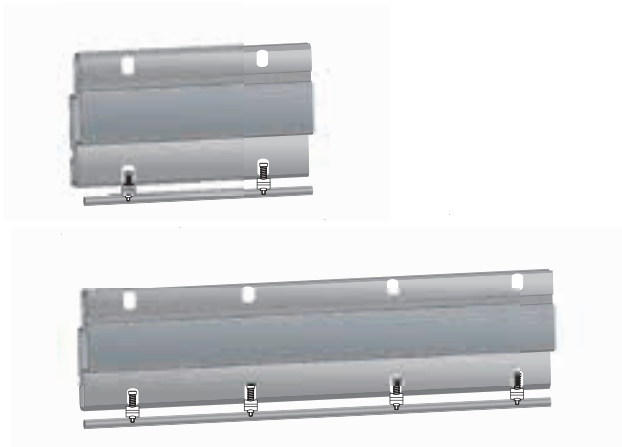

DIE SELECTION GUIDE

(Assumes air bending):

1) Select the V opening:

Calculate 2 times the punch radius plus 2 times the material thickness.

For example, a punch radius of 10mm and 2mm material = $(2 \times 10) + (2 \times 2) = 24\text{mm}$ V opening. When the exact V opening is not available, use the next nearest larger die.

2) Select the V angle:

It is recommended that the die V angle be smaller than the desired bend angle.

For example, to achieve a 90 degree bend, use a V angle less than 90 degrees such as a 60 degree, 45 degree or even a 30 degree.

If the result should be a 60 degree bend, use a die with a 45 degree or even a 30 degree angle.

If the result should be a 45 degree bend, use a die with a 30 degree angle.

Note that in general the material springback will be slightly greater using a radius punch than a standard punch.



HOLDERS FOR RADIUS/FLAT INSERTS

412 mm
830 mm

H	T/mt	Mt
10.115	67.00	100

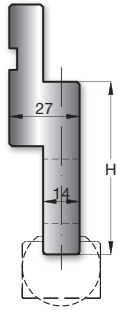

412 mm
830 mm

H	T/mt	Mt
10.116	115.00	100

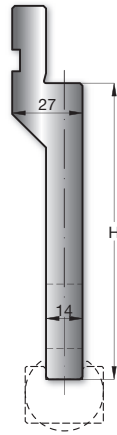

412 mm
830 mm

H	Mt
10.190	87.00 50

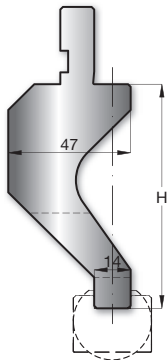

412 mm
830 mm

H	T/mt	Mt
10.191	115.00 50	

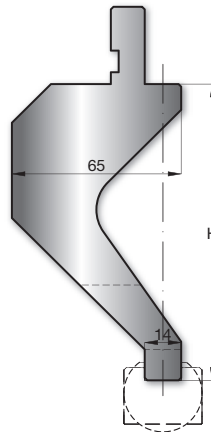

HALF LENGTH - (M)

STANDARD LENGTH - (S)

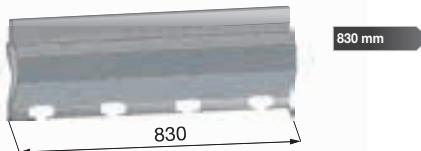
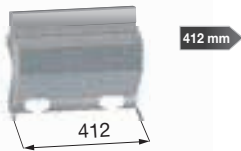

Refer to page 25 for die selection guide.



RADIUS/FLAT INSERTS

INSERTS

415 mm 835 mm

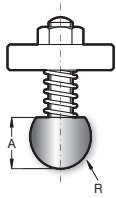

	R	A	B	Mt
10.300	7.00	11.50		▷
10.301	7.50	11.50		▷
10.302	8.00	13.00		▷
10.303	9.00	16.00		▷
10.304	10.00	16.00		▷
10.305	11.00	16.00		▷
10.306	11.50	19.00		▷
10.307	12.00	20.00		▷

415 mm 835 mm

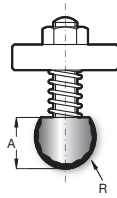

	R	A	B	Mt
11.300	7.00	11.50		▷
11.301	7.50	11.50		▷
11.302	8.00	13.00		▷
11.303	9.00	16.00		▷
11.304	10.00	16.00		▷
11.305	11.00	16.00		▷
11.306	11.50	19.00		▷
11.307	12.00	20.00		▷

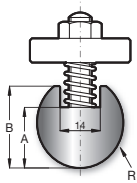

10.308	12.50	16.00	21.00	▷
10.309	13.00	17.00	23.00	▷
10.310	14.00	19.00	25.00	▷
10.311	15.00	20.00	27.00	▷
10.312	16.00	21.00	28.00	▷
10.313	17.00	21.50	31.50	▷
10.314	17.50	22.00	32.00	▷
10.315	19.00	25.00	32.00	▷
10.316	20.00	24.00	34.00	▷
10.317	22.50	25.00	33.00	▷
10.318	25.00	29.00	39.00	▷
10.319	27.50	34.00	44.00	▷
10.320	30.00	34.00	44.00	▷
10.321	35.00	45.00	55.00	▷
10.322	40.00	45.00	55.00	▷
10.323	45.00	50.00	60.00	▷
10.324	50.00	54.00	64.00	▷

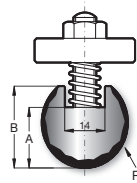

11.308	12.50	16.00	21.00	▷
11.309	13.00	17.00	23.00	▷
11.310	14.00	19.00	25.00	▷
11.311	15.00	20.00	27.00	▷
11.312	16.00	21.00	28.00	▷
11.313	17.00	21.50	31.50	▷
11.314	17.50	22.00	32.00	▷
11.315	19.00	25.00	32.00	▷
11.316	20.00	24.00	34.00	▷
11.317	22.50	25.00	33.00	▷
11.318	25.00	29.00	39.00	▷
11.319	27.50	34.00	44.00	▷
11.320	30.00	34.00	44.00	▷
11.321	35.00	45.00	55.00	▷
11.322	40.00	45.00	55.00	▷
11.323	45.00	50.00	60.00	▷
11.324	50.00	54.00	64.00	▷

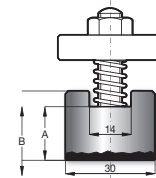

Radius insert sold with bolt assembly.

10.325	17.00	22.00	▷
--------	-------	-------	---

HALF LENGTH - (M)

415 mm

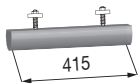

STANDARD LENGTH - (S)

835 mm

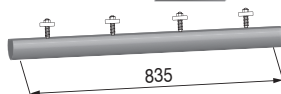

BOLT ASSEMBLY

40.002



ASSEMBLY SCHEME



MATERIAL TYPE

- Mt ▷ NON-HARDENED
- Mt ▷ STEEL C45 (UNI EN 10083 W.1. : 1.1191)
INDUCTION TEMPERED (58-60 HRC) ON WEAR PARTS
- Mt ▷ STEEL C45 (UNI EN 10083 W.1. : 1.1191)
HARDENED R=80-85 kg/mm² INDUCTION TEMPERED (58-60 HRC) ON WEAR PARTS
- Mt ▷ STEEL 42 CRMO4 (UNI EN 10083 W.1. : 1.7225)
HARDENED R=95-105 kg/mm² NITRIDED (58-60 HRC) ON WEAR PARTS



HOLDERS AND POLYURETHANE INSERTS



FOR USE WITH THIN AND DELICATE MATERIALS.

URETHANE HOLDER

415 mm
835 mm

20.271

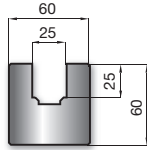

URETHANE

415 mm
835 mm

45.011



URETHANE WITH HOLE

415 mm
835 mm

45.015



URETHANE HOLDER

415 mm
835 mm

20.272

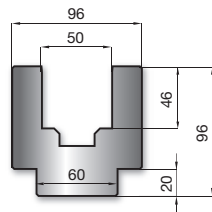

URETHANE

415 mm
835 mm

45.010

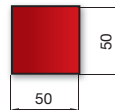

URETHANE WITH HOLE

415 mm
835 mm

45.014

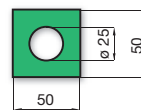

URETHANE HOLDER

415 mm
835 mm

20.273

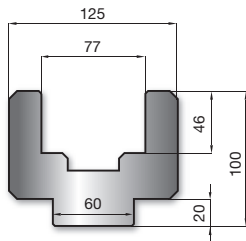

URETHANE

415 mm
835 mm

45.009

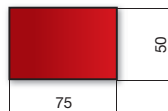

URETHANE WITH HOLE

415 mm
835 mm

45.013

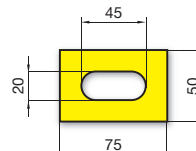

URETHANE HOLDER

415 mm
835 mm

20.274

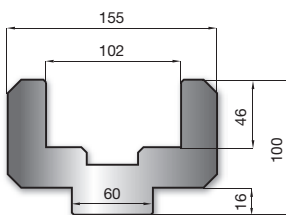

URETHANE

415 mm
835 mm

45.008

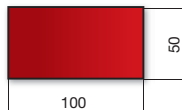

URETHANE WITH HOLE

415 mm
835 mm

45.012

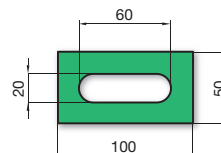

90A	Red	25% deflection	Mild steel
80A	Green	35% deflection	Aluminum
60A	Yellow	40% deflection	CU & Alum

DIES ARE AVAILABLE IN THE FOLLOWING STANDARD LENGTHS:

HALF LENGTH - (M)

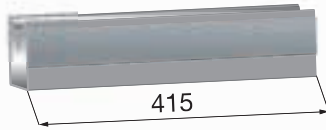

415 mm

STANDARD LENGTH - (S)

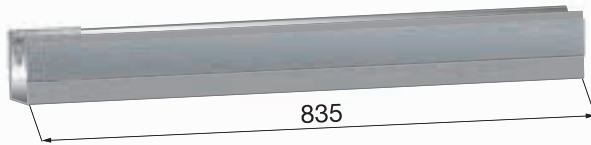

835 mm

SECTIONED LENGTH - (F)

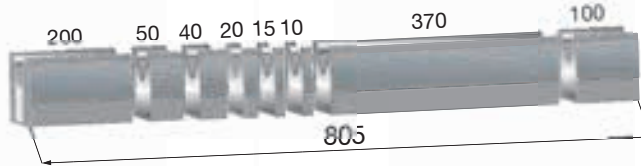

805 mm

OVERVIEW

SELF-CENTERING DIES

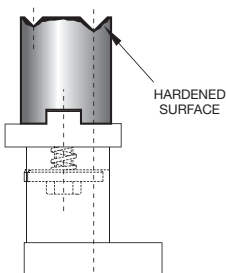

PILLAR DIES

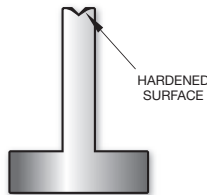

BOTTOM DIES

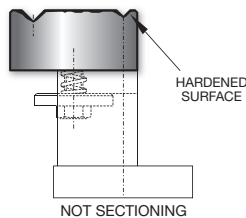

4V DIES

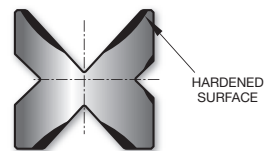

BOLT-ON STYLE 2V DIES

2V DIES DATA TABLE

415 mm

835 mm

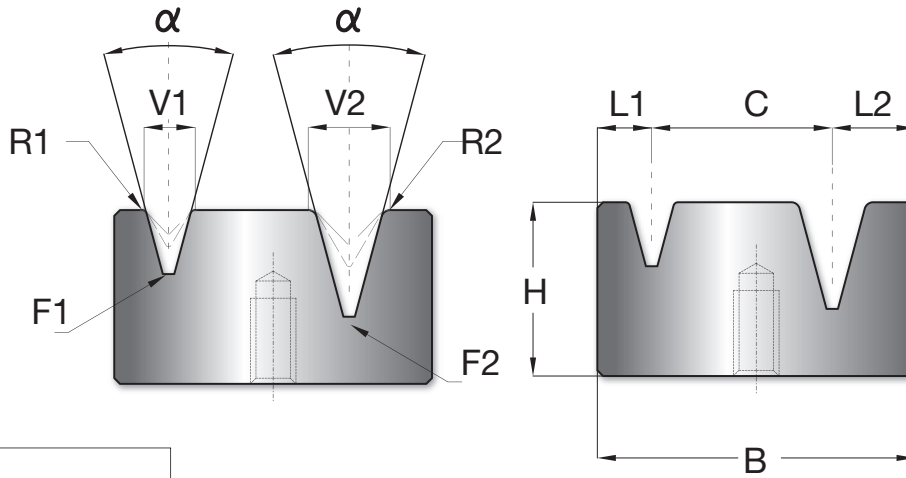

Legend	
F	= bottom
R	= radius
P	= flat

415 mm

835 mm

	α	V1	V2	R1	R2	F1	F2	L1	L2	H	B	C	T/m	Mt
20.295	90°	4	7	0,3	0,5	R 0,5	R 0,5	4	7	26	55	44	100	▶
20.202	90°	6	10	0,4	0,6	R 0,5	R 0,5	6	10	26	55	39	100	▶
20.203	90°	8	12	0,5	0,8	R 0,5	R 0,5	8	10	26	55	37	100	▶
21.202	88°	6	10	0,8	1,2	R 0,5	R 0,5	6	10	26	55	39	100	▶
20.338	88°	8	12	1,0	1,5	R 0,5	R 0,5	8	10	26	55	37	100	▶
20.204	88°	12	20	2,75	3,0	R 0,5	R 0,5	10	15	26	55	30	100	▶
20.296	88°	14	18	2,75	3,0	R 0,5	R 0,5	11	13	26	55	31	100	▶
20.205	88°	16	25	2,75	3,0	R 0,5	R 0,5	12	16,5	26	55	26,5	100	▶
20.235	60°	6	10	0,4	0,6	R 0,5	R 0,5	6	10	26	55	39	60	▶
20.229	60°	8	12	0,5	0,8	R 0,5	R 0,5	8	10	26	55	37	60	▶
20.230	60°	12	20	0,8	1,5	R 0,5	R 0,5	10	15	26	55	30	60	▶
20.267	60°	16	20	1,6	2,0	R 0,7	R 0,7	12	15	26	55	28	60	▶
20.418	30°	8	12	0,8	1,5	P 2,0	P 2,0	9,5	14,5	46	50	26	40	▶













90° 88° 60° 30°

BOLT ASSEMBLY

40.001



BOLT-ON STYLE 2V DIES

20.202		20.230		20.296	
20.203		20.235		20.338	
20.204		20.267		20.418	
20.205		20.295		21.202	
20.229					

HOLDERS/EXTENSIONS

415 mm
835 mm

	H1	H2	T/mt	Mt
20.200	34.00	20.00	100	▶

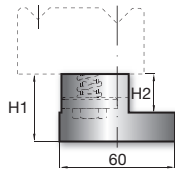

415 mm
835 mm

	H1	H2	T/mt	Mt
20.316	39.00	20.00	100	▶

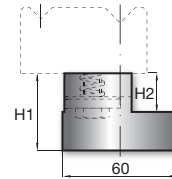

415 mm
835 mm

	H1	H2	T/mt	Mt
20.201	55.00	35.00	100	▶

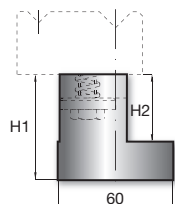

415 mm
835 mm

	H1	H2	T/mt	Mt
20.306	75.00	55.00	100	▶

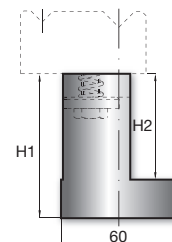

SELF-CENTERING 2V DIES

SELF-CENTERING 2V DIES

SELF-CENTERING 2V DIES DATA TABLE

415 mm
835 mm
805 mm

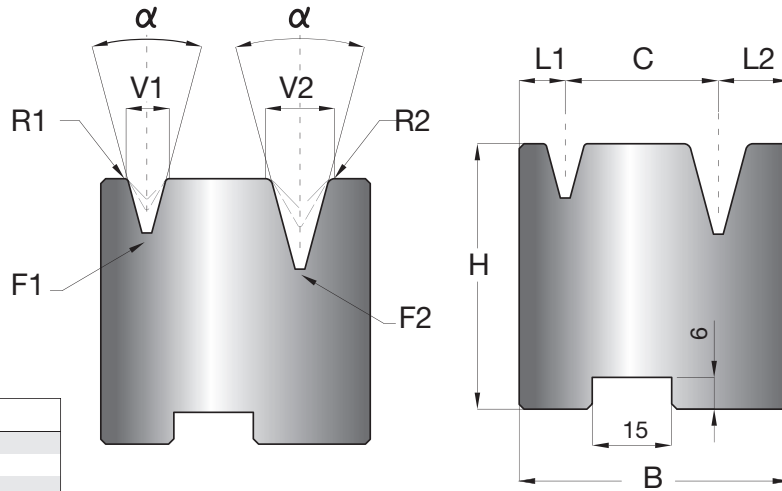

Legend	
F	= bottom
R	= radius
P	= flat

415 mm 835 mm 805 mm

	α	V1	V2	R1	R2	F1	F2	L1	L2	H	B	C	T/m	Mt
20.275	90°	4	7	0,3	0,5	R0,5	R0,5	3,5	5	46	34,5	26	80	▶
20.276	90°	6	10	0,4	0,6	R0,5	R0,5	4,5	6,5	46	37	26	80	▶
20.277	90°	8	12	0,5	0,8	R0,5	R0,5	5,5	7,5	46	39	26	80	▶
21.275	88°	4	7	0,6	1,0	R0,5	R0,5	3,5	5	46	34,5	26	80	▶
21.276	88°	6	10	0,8	1,2	R0,5	R0,5	4,5	6,5	46	37	26	80	▶
20.339	88°	8	12	1,0	1,5	R0,5	R0,5	5,5	7,5	46	39	26	80	▶
20.279	88°	12	20	0,8	1,75	R0,5	R0,5	7,5	12	46	45,5	26	80	▶
20.278	88°	14	18	1,25	1,5	R0,5	R0,5	8,5	10,5	46	45	26	80	▶
20.280	88°	16	25	1,5	1,75	R0,5	R0,5	9,5	14,5	46	50	26	80	▶
20.344	85°	4	7	0,6	1,0	R0,5	R0,5	3,5	5	46	34,5	26	80	▶
20.345	85°	6	10	1,0	1,5	R0,5	R0,5	4,5	6,5	46	37	26	80	▶
20.346	85°	8	12	1,2	1,75	R0,5	R0,5	5,5	7,5	46	39	26	80	▶
20.347	85°	12	20	1,75	2,5	R0,5	R0,5	7,5	12	46	45,5	26	80	▶
20.349	85°	14	18	1,50	2,0	R0,5	R0,5	8,5	10,5	46	45	26	80	▶
20.348	85°	16	25	2,0	3,0	R0,5	R1,0	9,5	14,5	46	50	26	80	▶
20.438	30°	6	10	0,6	1,0	R1,0	P2,0	7	12	46	45	26	40	▶
20.478	30°	8	12	0,8	1,5	P2,0	P2,0	9,5	14,5	46	50	26	40	▶

90° 88° 85° 30°



SELF-CENTERING 2V DIES

20.275		20.339		20.349	
20.276		20.344		20.438	
20.277		20.345		20.478	
20.278		20.346		21.275	
20.279		20.347		21.276	
20.280		20.348			

RAIL ADAPTER/END STOP

415 mm

835 mm

415 mm

835 mm

	H1	H2	T/mt	Mt
20.287	10.00	15.00	100	

	H1	H2	T/mt	Mt
20.400	20.00	25.00	100	

	H1	H2	T/mt	Mt
20.336	20.00	25.00	100	

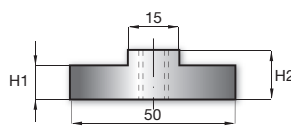

(Bolt assembly sold separately, see part number 40.001 on page 30)

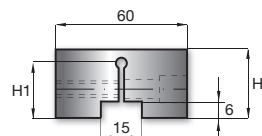
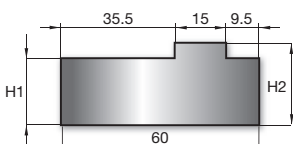

ASSEMBLY SCHEME

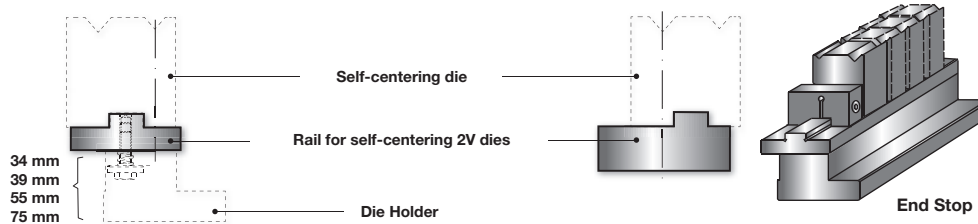

MULTI-V DIES

415 mm
835 mm
805 mm

α T/mt Mt

20.208 90° 80 ▶

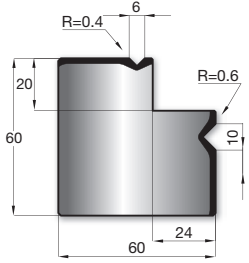

90°

415 mm
835 mm
805 mm

α T/mt Mt

20.237 90° 80 ▶

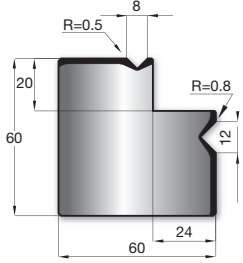

90°

415 mm
835 mm
805 mm

T/mt Mt

21.209 100 ▶

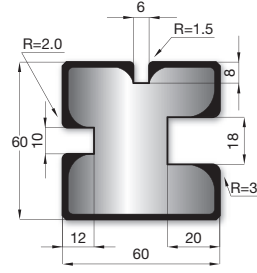

415 mm
835 mm
805 mm

α T/mt Mt

20.350 60° 60 ▶

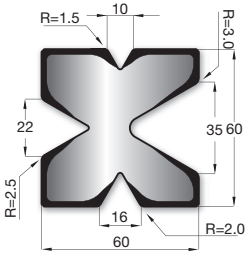

60°

415 mm
835 mm
805 mm

α T/mt Mt

21.207 85° 80 ▶

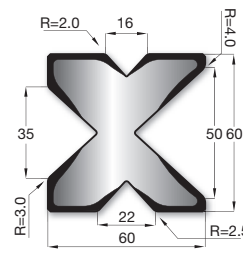

85°

415 mm
835 mm
805 mm

α R H T/mt Mt

20.494 30° 2.00 60.00 100 ▶

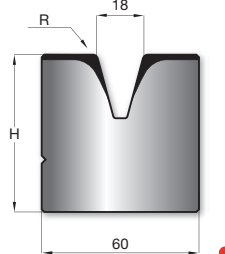

30°

415 mm
835 mm
805 mm

α H T/mt Mt

20.820 85° 80.00 100 ▶

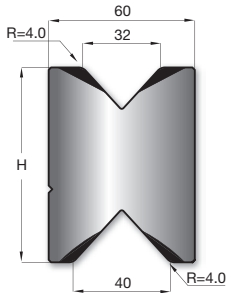

85°

415 mm
835 mm
805 mm

α H T/mt Mt

20.830 30° 80.00 100 ▶

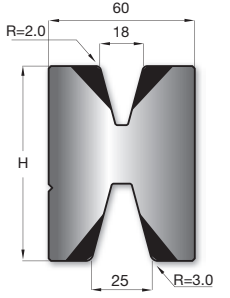

30°



1V DIES

415 mm
835 mm
805 mm

α R H T/mt Mt

20.325 30° 3.00 60.00 100 ▶

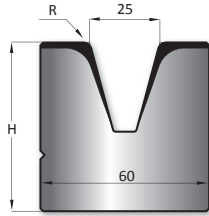

30°

415 mm
835 mm
805 mm

α R H T/mt Mt

20.210 85° 4.00 60.00 100 ▶

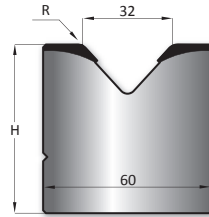

85°

415 mm
835 mm
805 mm

α R H T/mt Mt

20.484 45° 4.00 80.00 100 ▶

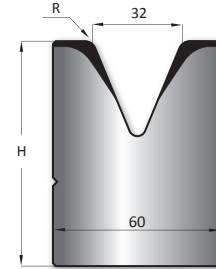

45°

415 mm
835 mm
805 mm

α R H T/mt Mt

20.211 85° 4.00 60.00 100 ▶

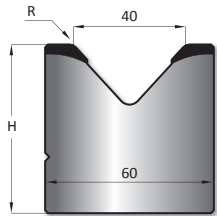

85°

415 mm
835 mm
805 mm

α R H T/mt Mt

20.440 45° 4.00 75.00 100 ▶

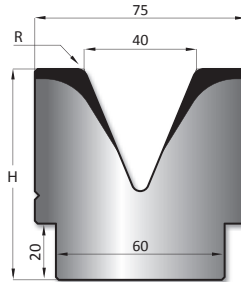

45°

415 mm
835 mm
805 mm

α R H T/mt Mt

20.212 85° 4.00 60.00 100 ▶

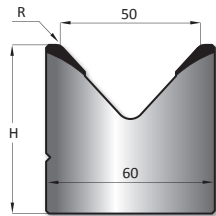

85°

415 mm
835 mm
805 mm

α R H T/mt Mt

20.650 60° 5.00 75.00 100 ▶

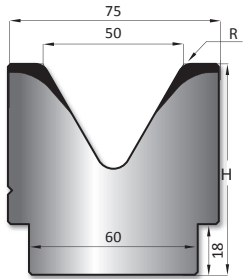

60°

415 mm
835 mm
805 mm

α R H T/mt Mt

20.213 85° 5.00 75.00 100 ▶

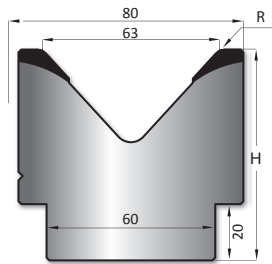

85°

415 mm
835 mm
805 mm

α R H T/mt Mt

20.370 60° 5.00 86.00 100 ▶

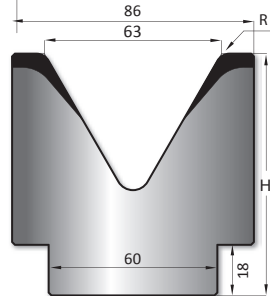

60°



1V DIES

415 mm

835 mm

805 mm

α R H T/mt Mt

20.214 85° 6.00 80.00 100 ▶

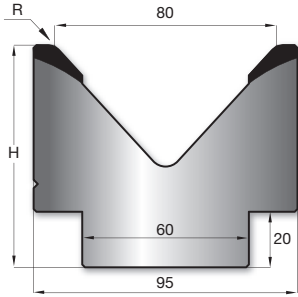

85°

415 mm

835 mm

805 mm

α R H T/mt Mt

20.680 60° 6.00 115.00 100 ▶

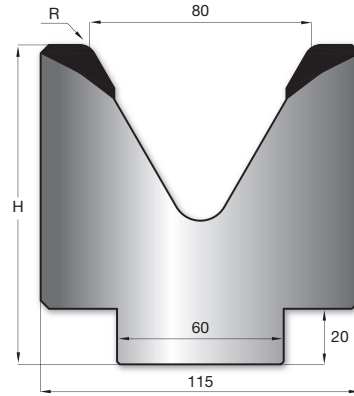

60°

415 mm

835 mm

805 mm

α R H T/mt Mt

20.380 45° 6.00 145.00 100 ▶

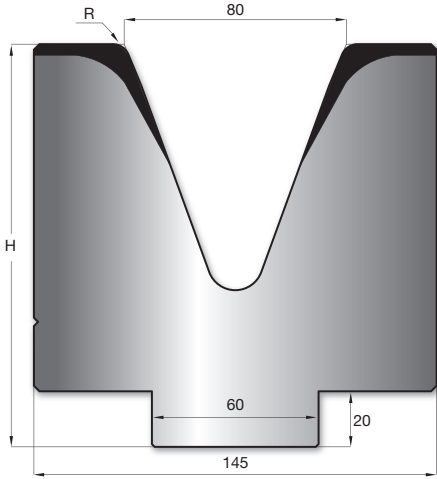

45°

415 mm

835 mm

805 mm

α R H T/mt Mt

20.215 85° 7.00 95.00 100 ▶

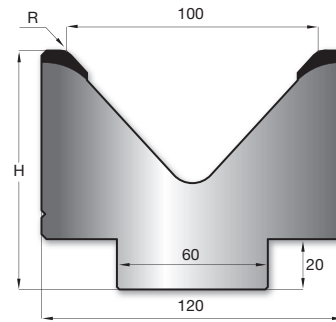

85°



415 mm
835 mm
805 mm

20.216 α R H T/mt Mt 80° 9.00 103.00 100 ▶

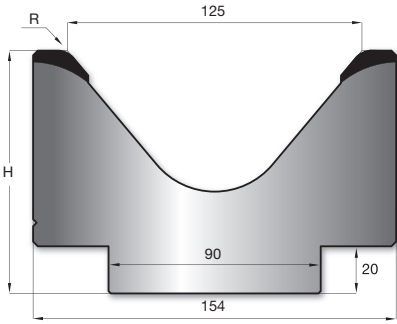

80°

415 mm
835 mm
805 mm

20.217 α R H T/mt Mt 80° 10.00 130.00 100 ▶

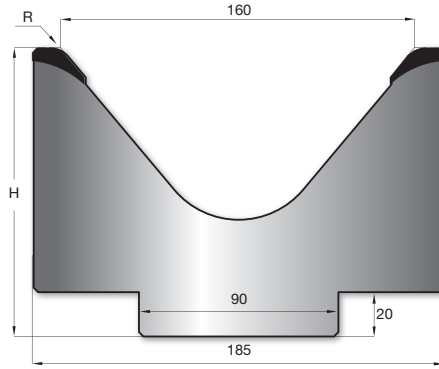

80°

415 mm
835 mm
805 mm

21.125 α R H T/mt Mt 80° 9.00 103.00 100 ▶

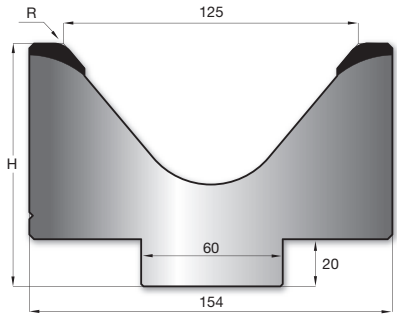

80°

415 mm
835 mm
805 mm

21.160 α R H T/mt Mt 80° 10.00 130.00 100 ▶

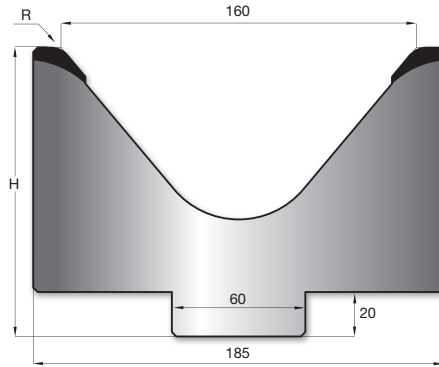

80°



PILLAR DIES H80

H=80

415 mm 835 mm 805 mm

Legend	
F	= bottom
R	= radius
P	= flat

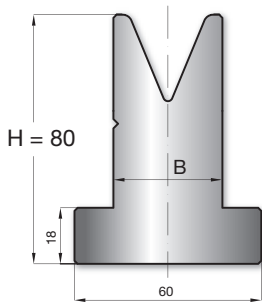
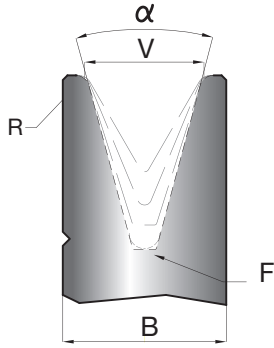

	α	V	R	B	F	T/m	Mt
20.243	90°	6	0,4	14	R 0,5	100	▶
20.258	90°	8	0,5	14	R 0,5	100	▶
20.244	90°	10	0,6	18	R 0,5	100	▶
20.245	90°	12	0,8	18	R 0,5	100	▶
20.246	90°	16	1,0	24	R 0,5	100	▶
20.806	88°	6	0,8	14	R 0,5	100	▶
20.808	88°	8	1,0	14	R 0,5	100	▶
20.810	88°	10	1,2	18	R 0,5	100	▶
20.371	88°	12	1,5	18	R 0,5	100	▶
20.327	88°	16	2,0	24	R 0,5	100	▶
20.310	88°	20	2,0	30	R 1,0	100	▶
20.309	88°	25	3,0	35	R 1,0	100	▶
20.506	85°	6	1,5	14	R 0,5	100	▶
20.508	85°	8	2,0	14	R 0,5	100	▶
20.510	85°	10	2,5	18	R 0,5	100	▶
20.512	85°	12	3,0	18	R 0,5	100	▶
20.516	85°	16	3,5	24	R 0,5	100	▶
20.520	85°	20	4,0	30	R 1,0	100	▶
20.525	85°	25	5,0	35	R 1,0	100	▶
20.297	60°	6	0,4	14	R 0,5	60	▶
20.298	60°	8	0,5	14	R 0,5	60	▶
20.299	60°	10	0,6	18	R 0,5	60	▶
20.300	60°	12	0,8	18	R 0,5	60	▶
20.301	60°	16	1,6	24	R 0,7	60	▶
20.308	60°	20	2,0	30	R 1,0	60	▶
20.311	60°	25	3,0	35	R 1,0	60	▶
20.328	45°	6	0,6	14	R 0,8	50	▶
20.329	45°	8	0,8	18	R 0,8	50	▶
20.330	45°	10	1,0	18	R 0,8	50	▶
20.331	45°	12	1,5	24	R 0,8	50	▶
20.332	45°	16	2,0	24	R 1,5	50	▶
20.333	45°	20	2,5	30	R 1,5	50	▶
20.334	45°	25	3,0	35	R 1,5	50	▶
20.406	35°	6	1,5	14	R 1,0	40	▶
20.408	35°	8	2,0	18	P 2,0	40	▶
20.410	35°	10	2,5	24	P 2,0	55	▶
20.412	35°	12	3,0	24	P 2,0	45	▶
20.416	35°	16	3,5	30	P 2,0	50	▶
20.420	35°	20	4,0	35	P 5,0	60	▶
20.425	35°	25	5,0	40	P 5,0	60	▶
20.317	30°	6	0,6	14	R 1,0	35	▶
20.318	30°	8	0,8	18	P 2,0	35	▶
20.319	30°	10	1,0	24	P 2,0	50	▶
20.320	30°	12	1,5	24	P 2,0	40	▶
20.321	30°	16	2,0	30	P 5,0	45	▶
20.322	30°	20	2,5	35	P 5,0	50	▶
20.323	30°	25	3,0	40	P 5,0	50	▶















































90° 88° 85° 60° 45° 35° 30°



PILLAR DIES H80

39

PILLAR DIES H80

20.243		20.319		20.410	
20.244		20.320		20.412	
20.245		20.321		20.416	
20.246		20.322		20.420	
20.258		20.323		20.425	
20.297		20.327		20.506	
20.298		20.328		20.508	
20.299		20.329		20.510	
20.300		20.330		20.512	
20.301		20.331		20.516	
20.308		20.332		20.520	
20.309		20.333		20.525	
20.310		20.334		20.806	
20.311		20.371		20.808	
20.317		20.406		20.810	
20.318		20.408			



PILLAR DIES H120

H=120

415 mm 835 mm 805 mm

Legend	
F	= bottom
R	= radius
P	= flat

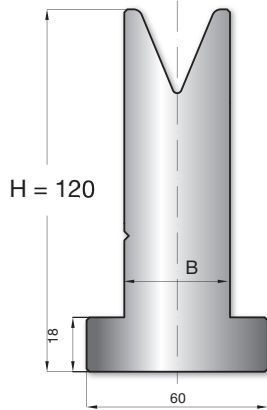
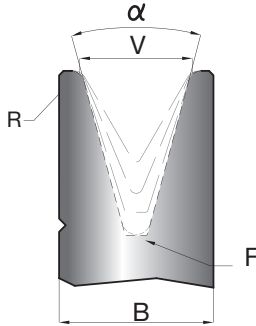















































	α	V	R	B	F	T/m	Mt
20.361	90°	6	0,4	14	R 0,5	100	▶
20.362	90°	8	0,5	14	R 0,5	100	▶
20.363	90°	10	0,6	18	R 0,5	100	▶
20.364	90°	12	0,8	18	R 0,5	100	▶
20.381	90°	16	1,0	24	R 0,5	100	▶
21.806	88°	6	0,8	14	R 0,5	100	▶
21.808	88°	8	1,0	14	R 0,5	100	▶
21.810	88°	10	1,2	18	R 0,5	100	▶
20.382	88°	12	1,5	18	R 0,5	100	▶
20.383	88°	16	2,0	24	R 0,5	100	▶
20.384	88°	20	2,0	30	R 1,0	100	▶
20.385	88°	25	3,0	35	R 1,0	100	▶
21.506	85°	6	1,5	14	R 0,5	100	▶
21.508	85°	8	2,0	14	R 0,5	100	▶
21.510	85°	10	2,5	18	R 0,5	100	▶
21.512	85°	12	3,0	18	R 0,5	100	▶
21.516	85°	16	3,5	24	R 0,5	100	▶
21.520	85°	20	4,0	30	R 1,0	100	▶
21.525	85°	25	5,0	35	R 1,0	100	▶
20.386	60°	6	0,4	14	R 0,5	60	▶
20.387	60°	8	0,5	14	R 0,5	60	▶
20.388	60°	10	0,6	18	R 0,5	60	▶
20.389	60°	12	0,8	18	R 0,5	60	▶
20.390	60°	16	1,6	24	R 0,7	60	▶
20.391	60°	20	2,0	30	R 1,0	60	▶
20.392	60°	25	3,0	35	R 1,0	60	▶
20.393	45°	6	0,6	14	R 0,8	50	▶
20.394	45°	8	0,8	18	R 0,8	50	▶
20.395	45°	10	1,0	18	R 0,8	50	▶
20.396	45°	12	1,5	24	R 0,8	50	▶
20.397	45°	16	2,0	24	R 1,5	50	▶
20.398	45°	20	2,5	30	R 1,5	50	▶
20.399	45°	25	3,0	35	R 1,5	50	▶
21.406	35°	6	1,5	14	R 1,0	40	▶
21.408	35°	8	2,0	18	P 2,0	40	▶
21.410	35°	10	2,5	24	P 2,0	55	▶
21.412	35°	12	3,0	24	P 2,0	45	▶
21.416	35°	16	3,5	30	P 2,0	50	▶
21.420	35°	20	4,0	35	P 5,0	60	▶
21.425	35°	25	5,0	40	P 5,0	60	▶
20.351	30°	6	0,6	14	R 1,0	35	▶
20.352	30°	8	0,8	18	P 2,0	35	▶
20.353	30°	10	1,0	24	P 2,0	50	▶
20.354	30°	12	1,5	24	P 2,0	40	▶
20.401	30°	16	2,0	30	P 5,0	45	▶
20.402	30°	20	2,5	35	P 5,0	50	▶
20.403	30°	25	3,0	40	P 5,0	50	▶

90° 88° 85° 60° 45° 35° 30°



PILLAR DIES H120

20.351		20.389		21.410	
20.352		20.390		21.412	
20.353		20.391		21.416	
20.354		20.392		21.420	
20.361		20.393		21.425	
20.362		20.394		21.506	
20.363		20.395		21.508	
20.364		20.396		21.510	
20.381		20.397		21.512	
20.382		20.398		21.516	
20.383		20.399		21.520	
20.384		20.401		21.525	
20.385		20.402		21.806	
20.386		20.403		21.808	
20.387		21.406		21.810	
20.388		21.408			



DIE INSERTS

DIE INSERTS DATA TABLE

- 415 mm ▶
- 835 mm ▶▶
- 805 mm ▶▶▶

Legend	
F	= bottom
R	= radius
P	= flat

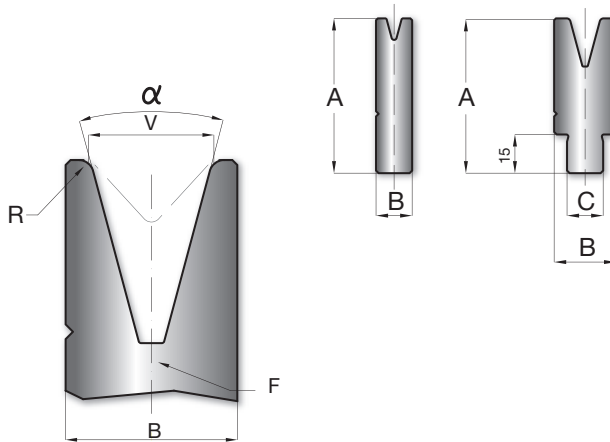

- 415 mm ▶
- 835 mm ▶▶
- 805 mm ▶▶▶

	V	α	A	B	C	R	F	T/m	Mt
22.804	4	88°	60	14	/	0,6	R0,5	100	▶
22.806	6	88°	60	14	/	0,8	R0,5	100	▶
22.808	8	88°	60	14	/	1,0	R0,5	100	▶
22.810	10	88°	60	18	14	1,2	R0,5	100	▶
22.812	12	88°	60	18	14	1,5	R0,5	100	▶
22.816	16	88°	60	24	14	2,0	R0,5	100	▶
22.820	20	88°	60	30	14	2,0	R1,0	100	▶
22.825	25	88°	60	35	14	3,0	R1,0	100	▶
22.306	6	30°	60	14	/	0,6	R1,0	35	▶
22.308	8	30°	60	18	14	0,8	P2,0	35	▶
22.310	10	30°	60	24	14	1,0	P2,0	50	▶
22.312	12	30°	60	24	14	1,5	P2,0	40	▶
22.316	16	30°	60	30	14	2,0	P5,0	45	▶
22.320	20	30°	60	35	14	2,5	P5,0	50	▶
22.325	25	30°	65	45	14	3,0	P8,0	50	▶

88° 30°



DIE INSERTS HOLDER

22.306		22.320		22.810	
22.308		22.325		22.812	
22.310		22.804		22.816	
22.312		22.806		22.820	
22.316		22.808		22.825	

DIE INSERTS HOLDER

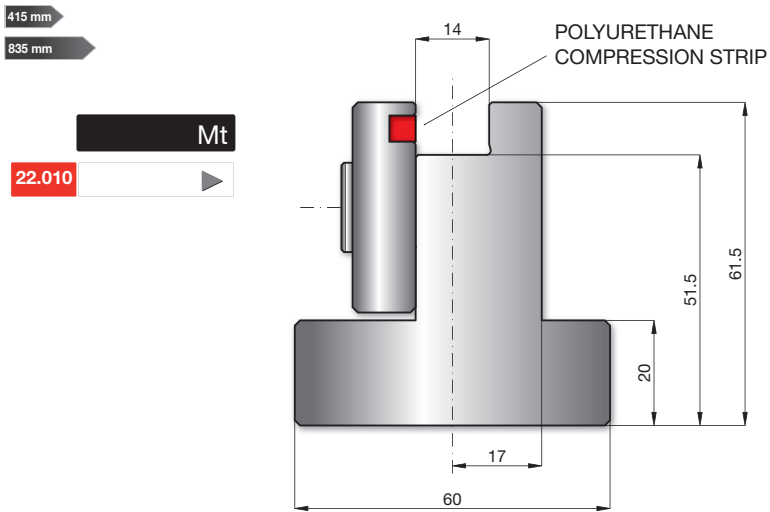

Polyurethane compression strip is especially helpful when clamping segmented die inserts.

HALF LENGTH (M)

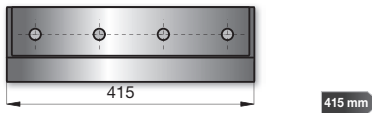

STANDARD LENGTH (S)

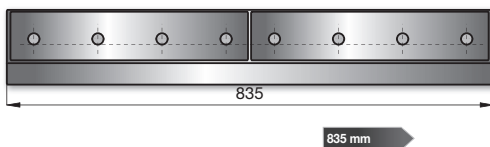

ASSEMBLY SCHEME

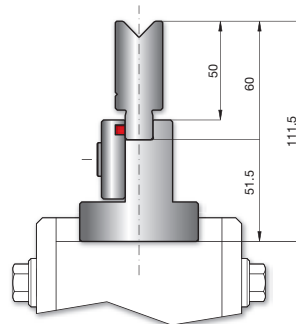

NYLON INSERT HOLDERS

NYLON INSERT HOLDERS

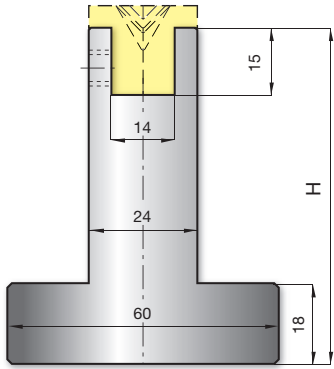

415 mm
835 mm

	H	Mt
22.001	75.00	▶

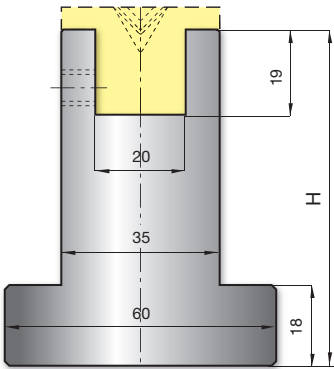

415 mm
835 mm

	H	Mt
22.002	75.00	▶

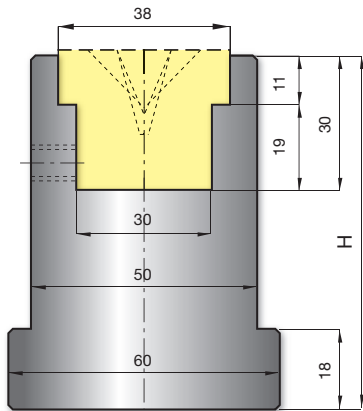

415 mm
835 mm

	H	Mt
22.003	79.00	▶



NYLON INSERTS

	V	α
31.306	6	30°
31.308	8	30°
31.406	6	45°
31.408	8	45°
31.410	10	45°

	V	α
31.606	6	60°
31.608	8	60°
31.610	10	60°
31.806	6	88°
31.808	8	88°
31.810	10	88°

SMALL

415 mm
835 mm

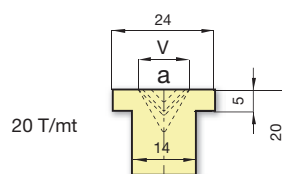

	V	α
32.306	6	30°
32.308	8	30°
32.310	10	30°
32.406	6	45°
32.408	8	45°
32.410	10	45°
32.412	12	45°

	V	α
32.606	6	60°
32.608	8	60°
32.610	10	60°
32.612	12	60°
32.616	16	60°
32.806	6	88°
32.808	8	88°
32.810	10	88°
32.812	12	88°
32.816	16	88°

MEDIUM

415 mm
835 mm

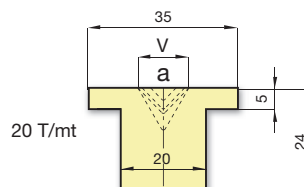

	V	α
33.306	6	30°
33.308	8	30°
33.310	10	30°
33.312	12	30°
33.316	16	30°
33.406	6	45°
33.408	8	45°
33.410	10	45°
33.412	12	45°
33.416	16	45°
33.420	20	45°

	V	α
33.606	6	60°
33.608	8	60°
33.610	10	60°
33.612	12	60°
33.616	16	60°
33.620	20	60°
33.806	6	88°
33.808	8	88°
33.810	10	88°
33.812	12	88°
33.816	16	88°
33.820	20	88°
33.825	25	88°

LARGE

415 mm
835 mm

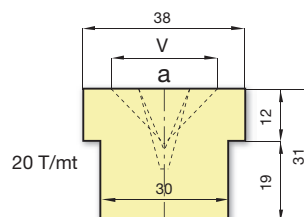

HEMMING TOOLS

- 415 mm
- 835 mm
- 805 mm

	α	R	H	Z	C	T/mt	Mt
11.550	24°	0.60	128.00	8	10	80	▶
11.554	24°	0.60	128.00	10	11	80	▶
11.560	24°	0.60	128.00	12	10	80	▶

Z8 = Maximum material thickness 1mm
 Z10 = Maximum material thickness 1,5mm
 Z12 = Maximum material thickness 2mm

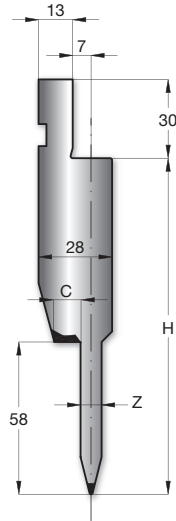

24°

- 415 mm
- 835 mm
- 805 mm

	R	H	Z	T/mt	Mt
20.550	1.00	80.00	8.2	50	▶
20.554	1.00	80.00	10.2	50	▶
20.560	1.00	80.00	12.2	50	▶

Z8.2 = Maximum material thickness 1mm
 Z10.2 = Maximum material thickness 1,5mm
 Z12.2 = Maximum material thickness 2mm

Close-up view of top of hemming die

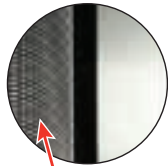

Knurled edge to prevent movement

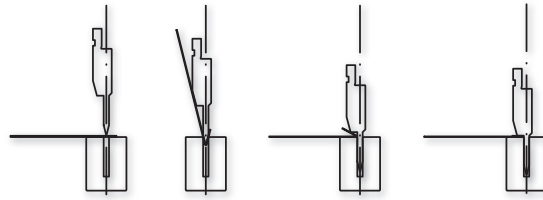
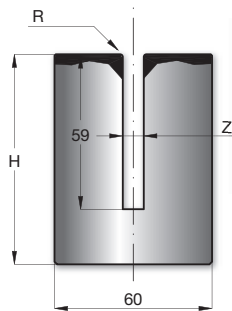

HORNS SCHEME STANDARD SECTIONING

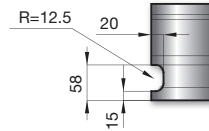

HALF LENGTH - (M)

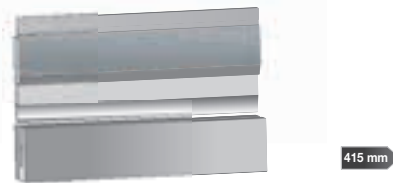

STANDARD LENGTH - (S)

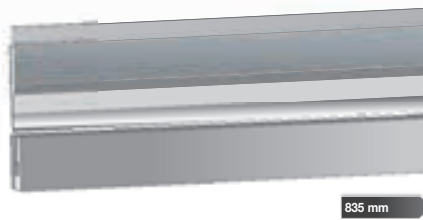

SECTIONED LENGTH - (F)

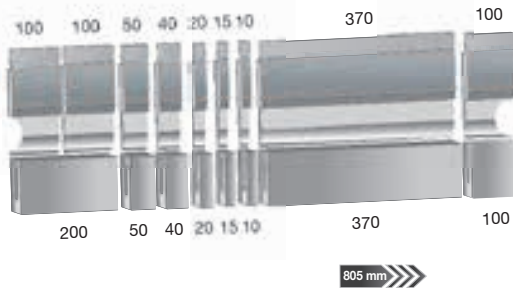

BENDING SCHEME

MATERIAL - ACC. R ~ 40 Kg/mm²

S (mm)	(t/m)	T (mm)	(t/m)	2S (mm)
0,6	9	3	23	1,2
0,8	12	3	32	1,6
1,0	15	3,5	40	2,0
1,25	17	3,5	50	2,5
1,5	22	4,6	63	3,0
2,0	30	5,5	80	4,0
2,5	55	6,5	90	5,0
3,0	70	8,0	100	6,0

MATERIAL - ACC. R ~ 70 Kg/mm²

S (mm)	(t/m)	T (mm)	(t/m)	2S (mm)
0,6	15	3	35	1,2
0,8	20	3	50	1,6
1,0	25	3,5	60	2,0
1,25	26	3,5	80	2,5
1,5	38	4,6	95	3,0
2,0	50	5,5	130	4,0

SPARE PARTS

70.100



70.102

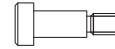

415 mm

835 mm

α R T/mt Mt

20.264 35° 1.00 60

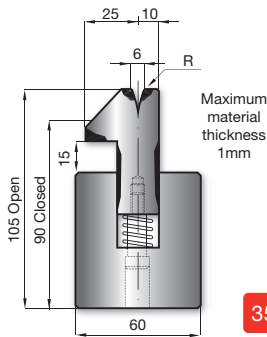

35°

415 mm

835 mm

α R T/mt Mt

20.303 30° 1.50 80

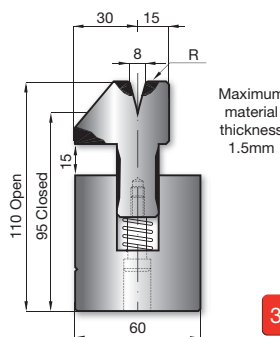

30°

415 mm

835 mm

α R T/mt Mt

20.450 30° 1.50 60

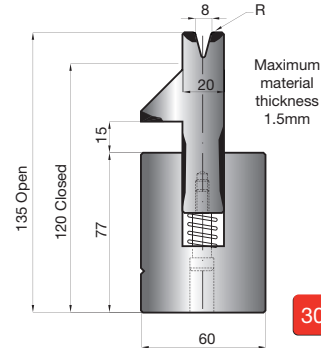

30°

415 mm

835 mm

α R T/mt Mt

20.231 26° 1.50 100

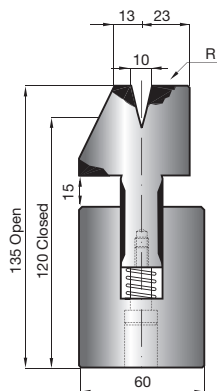

26°

415 mm

835 mm

α R T/mt Mt

20.305 26° 3.00 100

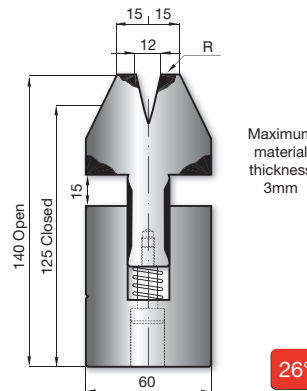

26°



ACCESSORIES — POLYURETHANE FILM AND HOLDERS

ANTI-SCRATCH POLYURETHANE FILM

- Excellent protection against die marks and scratches.
- Economical solution for mar-free bending pre-finished, pre-polished stainless steel, brass, aluminum or pre-painted metal.
- Help protect your dies. Quick setup, universal, saves time and money.

WHITE ANTI-SCRATCH POLYURETHANE FILM

- Standard performance
- White
- Extruded



100 FEET

45.001

Thickness= 0.015 inches
Width= 4 inches
Length= 100 feet

100 FEET

45.002

Thickness= 0.015 inches
Width= 6 inches
Length= 100 feet

100 FEET

45.003

Thickness= 0.030 inches
Width= 4 inches
Length= 100 feet

100 FEET

45.004

Thickness= 0.030 inches
Width= 6 inches
Length= 100 feet



MAGNETIC POLYURETHANE FILM HOLDER

40.850

MAGNETIC ATTACHMENT

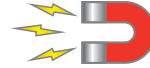

STANDARD POLYURETHANE FILM HOLDER - MECHANICAL

40.800

RAIL ATTACHMENT

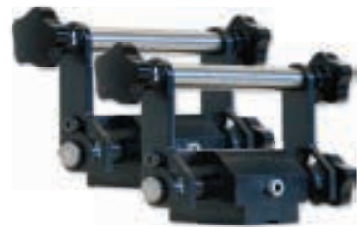

ACCESSORIES — REFERENCE SQUARES

SQUARING

For use with long, narrow bends

REFERENCE SQUARES STANDARD

40.660



REFERENCE SQUARES ADJUSTABLE

40.700



ANGLE

For use with angled bends

40.740



40.740



40.745



EUROPEAN PRECISION STYLE ADAPTERS

150 mm

	L	H	T/mt	Mt
50.671	150	100.00	100	▶

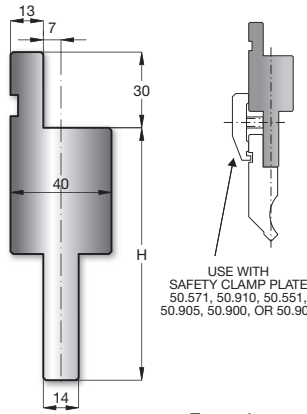

Extension
(Manual Adapter)

USE WITH
SAFETY CLAMP PLATE
50.571, 50.910, 50.551,
50.905, 50.900, OR 50.903

150 mm

	L	H	T/mt	Mt
50.959	150	60.00	100	▶

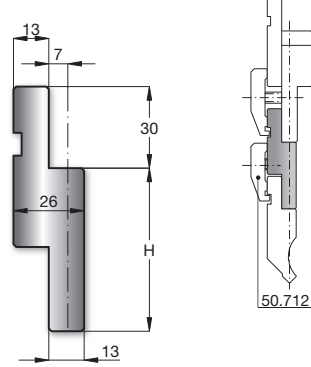

Extension
(Manual Adapter)

50.712

150 mm

	L	H	T/mt	Mt
50.666	150	100.00	100	▶
50.668	150	120.00	100	▶
50.512	150	150.00	100	▶

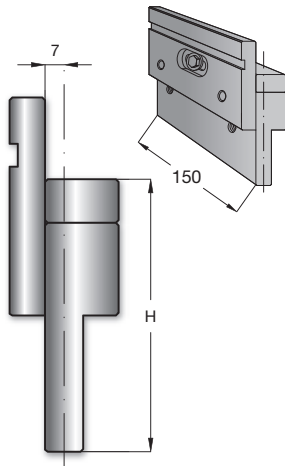

CLAMP PLATES NOT INCLUDED

Extension
(Adjustable Adapter)

150 mm

	L	H	T/mt	Mt
50.667	150	120.00	100	▶
50.669	150	150.00	100	▶

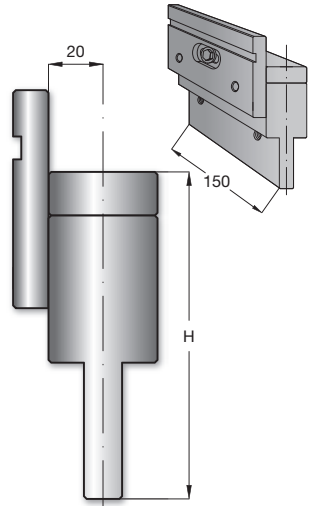

CLAMP PLATES NOT INCLUDED

Extension
(Adjustable Adapter)

CLAMP QUANTITY GUIDE

LENGTH	QUANTITY
1000mm	5
2100mm	10
3100mm	15
4100mm	20



CLAMP PLATES

CLAMP PLATES FOR ADAPTERS – L=150mm

CLAMP PLATES INCLUDE 2 BOLTS, 2 SPRINGS, 1 CLAMP

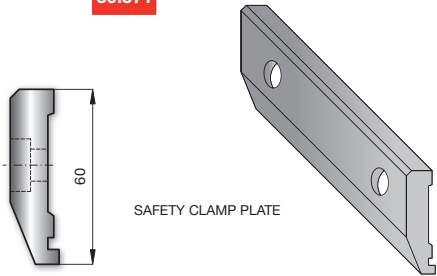
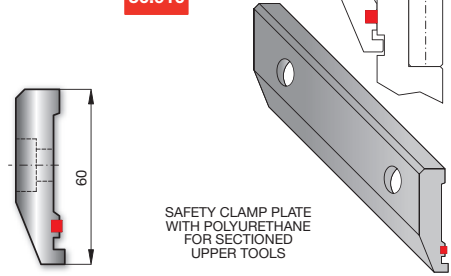
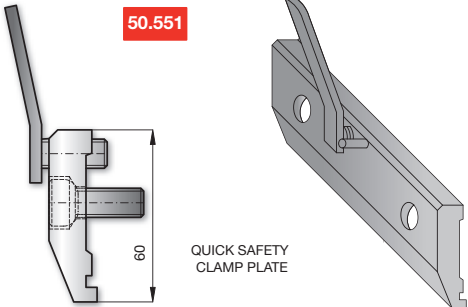
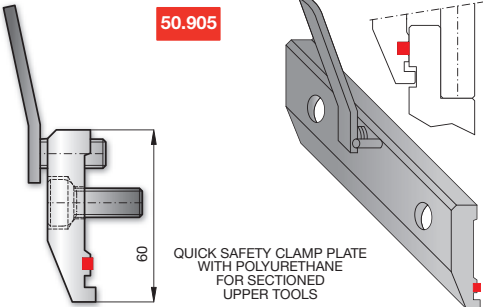
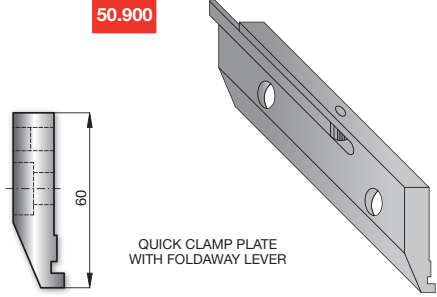
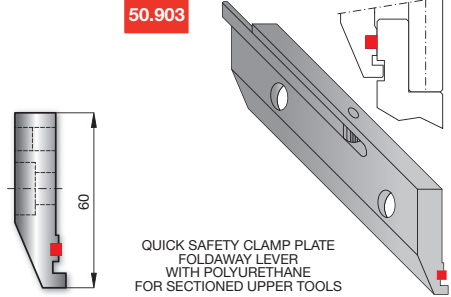
<p>50.571</p>  <p>SAFETY CLAMP PLATE</p>	<p>50.910</p>  <p>SAFETY CLAMP PLATE WITH POLYURETHANE FOR SECTIONED UPPER TOOLS</p>
<p>50.551</p>  <p>QUICK SAFETY CLAMP PLATE</p>	<p>50.905</p>  <p>QUICK SAFETY CLAMP PLATE WITH POLYURETHANE FOR SECTIONED UPPER TOOLS</p>
<p>50.900</p>  <p>QUICK CLAMP PLATE WITH FOLDAWAY LEVER</p>	<p>50.903</p>  <p>QUICK SAFETY CLAMP PLATE FOLDAWAY LEVER WITH POLYURETHANE FOR SECTIONED UPPER TOOLS</p>

EQUIPMENT FOR DOUBLE CLAMPING PLATE – L=150mm

INCLUDES 2 BOLTS, 2 SPRINGS, 1 CLAMP, 2 NUTS

50.577

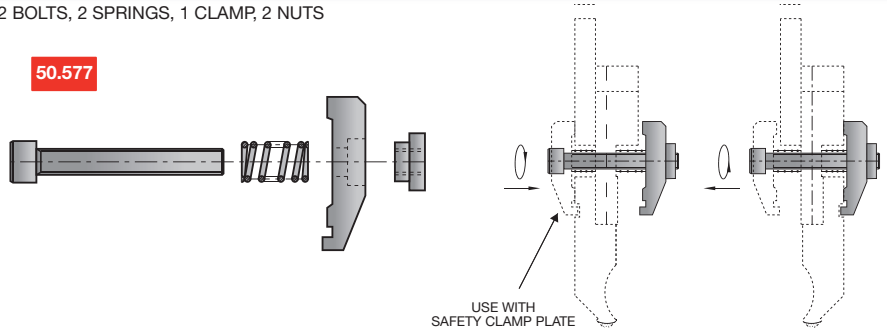

USE WITH SAFETY CLAMP PLATE 50.571, 50.910, 50.551, 50.905, 50.900, OR 50.903

CLAMP QUANTITY GUIDE	
LENGTH	QUANTITY
1000mm	5
2100mm	10
3100mm	15
4100mm	20



ACCESSORIES — CLAMPS AND DIE EXTENSIONS

SWING™

OPERATION ILLUSTRATION

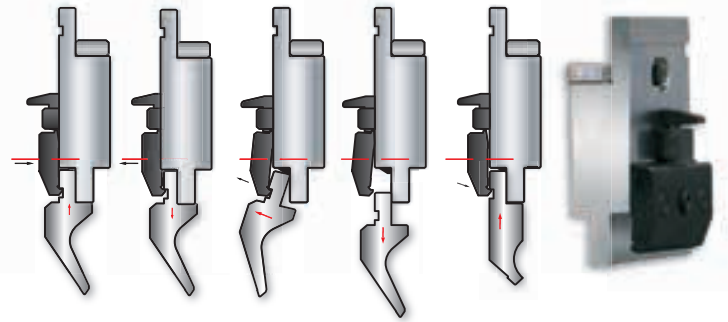

YouTube Video
SWING™
Fast Manual Clamping

SWING™ FAST MANUAL CLAMPING EUROPEAN PRECISION STYLE

150 mm	L	H	T/mt	Mt
50.200	150	100.00	100	▶
50.210	150	120.00	100	▶
50.220	150	150.00	100	▶

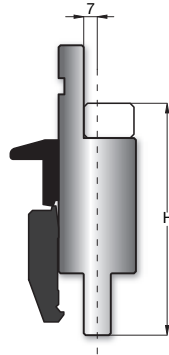

150 mm	L	H	T/mt	Mt
50.250	150	150.00	100	▶

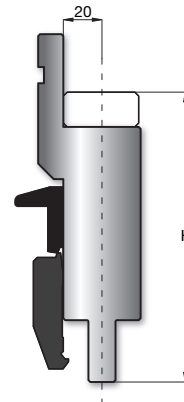

EUROPEAN PRECISION STYLE DIE EXTENSION

415 mm	835 mm	L	H	T/mt	Mt
60.919	835	55.00	100	▶	

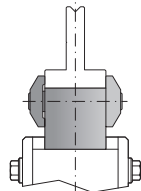
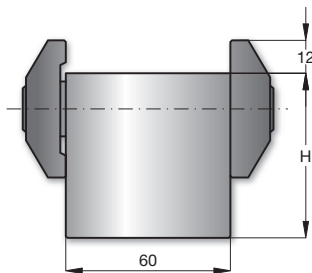

INCLUDES (2) CLAMPS WITH HARDWARE
(1) 50.861 AND (1) 50.860

CLAMP PLATES FOR DIE EXTENSION

50.861

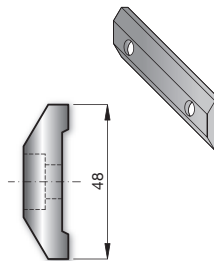

CLAMP PLATE FOR DIE EXTENSION

50.860

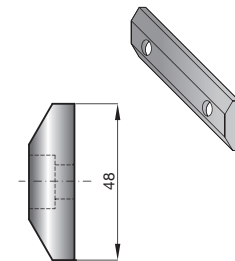

CLAMP PLATE FOR DIE EXTENSION

General guideline: 5 clamps per meter.

CLAMP QUANTITY GUIDE

LENGTH	QUANTITY
1000mm	5
2100mm	10
3100mm	15
4100mm	20



INCH TO METRIC / METRIC TO INCH REFERENCE GUIDE

CONVERSION CHART

mm	inch
0.01mm	0.0004
0.02mm	0.0008
0.03mm	0.0012
0.04mm	0.0016
0.05mm	0.0020
0.06mm	0.0024
0.07mm	0.0028
0.08mm	0.0031
0.09mm	0.0035
0.10mm	0.0039
0.25mm	0.0098
0.50mm	0.0197
0.75mm	0.0295
1.00mm	0.0394
1.50mm	0.0591
2.00mm	0.0787
2.50mm	0.0984
3.00mm	0.1181
3.50mm	0.1378
4.00mm	0.1575
4.50mm	0.1772
5.00mm	0.1969
6.00mm	0.2362
7.00mm	0.2756
8.00mm	0.3150
9.00mm	0.3543
10.00mm	0.3937
11.00mm	0.4331
12.00mm	0.4724
13.00mm	0.5118
14.00mm	0.5512
15.00mm	0.5906
16.00mm	0.6299
17.00mm	0.6693
18.00mm	0.7087
19.00mm	0.7480
20.00mm	0.7874
21.00mm	0.8268
22.00mm	0.8661
23.00mm	0.9055
24.00mm	0.9449
25.00mm	0.9843
26.00mm	1.0236
27.00mm	1.0630
28.00mm	1.1024
29.00mm	1.1417
30.00mm	1.1811
31.00mm	1.2205
32.00mm	1.2598
33.00mm	1.2992
34.00mm	1.3386
35.00mm	1.3780
36.00mm	1.4173
37.00mm	1.4567
38.00mm	1.4961
39.00mm	1.5354
40.00mm	1.5748
50.00mm	1.9685
60.00mm	2.3622
65.00mm	2.5591
70.00mm	2.7559
75.00mm	2.9528
80.00mm	3.1496
90.00mm	3.5433
100.00mm	3.9370

inch	inch	mm
	0.0001	0.003mm
	0.0010	0.03mm
	0.0020	0.05mm
	0.0030	0.08mm
	0.0040	0.10mm
	0.0050	0.13mm
1/128	0.0078	0.20mm
	0.0100	0.25mm
	0.0120	0.30mm
	0.0150	0.38mm
1/64	0.0156	0.40mm
	0.0300	0.76mm
1/32	0.0313	0.79mm
3/64	0.0469	1.19mm
	0.0600	1.52mm
1/16	0.0625	1.59mm
5/64	0.0781	1.98mm
	0.0900	2.29mm
3/32	0.0938	2.38mm
7/64	0.1094	2.78mm
	0.1200	3.05mm
1/8	0.1250	3.18mm
9/64	0.1406	3.57mm
5/32	0.1563	3.97mm
3/16	0.1875	4.76mm
7/32	0.2188	5.56mm
1/4	0.2500	6.35mm
9/32	0.2813	7.14mm
5/16	0.3125	7.94mm
3/8	0.3750	9.53mm
7/16	0.4375	11.11mm
1/2	0.5000	12.70mm
9/16	0.5625	14.29mm
5/8	0.6250	15.88mm
3/4	0.7500	19.05mm
7/8	0.8750	22.23mm
1 1/8	1.1250	28.58mm
1 1/4	1.2500	31.75mm
1 1/2	1.5000	38.10mm
1 3/4	1.7500	44.45mm
2	2.0000	50.80mm
2 1/4	2.2500	57.15mm
2 1/2	2.5000	63.50mm
2 3/4	2.7500	69.85mm
3	3.0000	76.20mm
3 1/2	3.5000	88.90mm
4	4.0000	101.60mm
4 1/2	4.5000	114.30mm
5	5.0000	127.00mm
5 1/2	5.5000	139.70mm
6	6.0000	152.40mm
12	12.0000	304.80mm

inch	mm
0.0001	0.003mm
0.0010	0.025mm
0.0100	0.254mm
0.1000	2.54mm
1.0000	25.40mm

mm	inch
0.01mm	0.0004
0.10mm	0.0039
1.00mm	0.0394

mm	inch	feet
1000mm	39.4	3.3
1050mm	41.3	3.4
1250mm	49.2	4.1
1500mm	59.1	4.9
2000mm	78.7	6.6
2050mm	80.7	6.7
2500mm	98.4	8.2
3000mm	118.1	9.8
3050mm	120.1	10.0
3500mm	137.8	11.5
4000mm	157.5	13.1
4050mm	159.4	13.3
4500mm	177.2	14.8
5000mm	196.9	16.4

feet	inch	mm
1 ft	12 inch	305mm
2 ft	24 inch	610mm
3 ft	36 inch	914mm
4 ft	48 inch	1219mm
5 ft	60 inch	1524mm
6 ft	72 inch	1829mm
7 ft	84 inch	2134mm
8 ft	96 inch	2438mm
9 ft	108 inch	2743mm
10 ft	120 inch	3048mm
11 ft	132 inch	3353mm
12 ft	144 inch	3658mm



	gauge size	aluminum & brass	mild steel	stainless steel
metal gauges	8GA	.129(3.28)	.164(4.17)	.172(4.37)
	9GA	.114(2.90)	.150(3.81)	.156(3.96)
	10GA	.102(2.59)	.135(3.43)	.141(3.58)
	11GA	.091(2.31)	.120(3.05)	.125(3.18)
	12GA	.081(2.06)	.105(2.67)	.109(2.77)
	13GA	.072(1.83)	.090(2.29)	.094(2.39)
	14GA	.064(1.63)	.075(1.91)	.078(1.98)
	16GA	.051(1.30)	.060(1.52)	.063(1.60)
	18GA	.040(1.02)	.048(1.22)	.050(1.27)
	20GA	.032(0.81)	.036(0.91)	.038(0.97)
	22GA	.025(0.64)	.030(0.76)	.031(0.79)
	24GA	.020(0.51)	.024(0.61)	.025(0.64)
26GA	.016(0.41)	.018(0.46)	.019(0.48)	
28GA	.013(0.33)	.015(0.38)	.016(0.41)	



SOLUTION GALLERY







visit mate.com

MATE PRECISION TOOLING

WORLDWIDE HEADQUARTERS:

1295 Lund Boulevard, Anoka, Minnesota 55303 USA
Tel +1.763.421.0230 Fax +1.763.421.0285 mate.com

The Mate Logo is a registered trademark of Mate Precision Tooling Inc.
Amada Promecam is a registered trademark of Amada Europe Corporation.
Trumpf is a registered trademark of Trumpf GMBH & Co.
Wila is a registered trademark of WILA B.V.